



EQUIPMENT

Dosing

CONTROL

REGULATE

EMPTY

EXTRACT



Powder Handling Solutions

CONTENT



Means that the equipment is available for testing at PALAMATIC PROCESS



Means that the equipment can be installed in ATEX zone



Means that design and options can be customised

PALAMATIC PROCESS reserves the right to make changes in the design of the facilities listed in this commercial documentation



RANGE OF SCREW FEEDERS	04
Volumetric	05
Weighing system	12
Disassembly and cleaning	14
BELT FEEDER	16
VIBRATING FEEDER	17
EXAMPLES OF IMPLEMENTATION	18
RANGE OF ROTARY AIRLOCKS	19
Drop through rotary airlock feeder	20
Blow through rotary airlock feeder	26
Wood pellets applications	34
Dust collection	36
Examples of implementations	38
RANGE OF VALVES	39
Rotary valve	40
Butterfly valve	42
Slide gate valve	46
Pinch valve	50
Examples of implementations	52
AUTOMATION	53

PALAMATIC PROCESS HAS DEVELOPED A WIDE RANGE OF DOSING EQUIPMENT TO MEET THE NEEDS OF ALL INDUSTRY AREAS

OBJECTIVES & ADVANTAGES OF THE PALAMATIC PROCESS RANGE

- To get a precise batch
- Regulation for powder introduction into process
- Operator's time saving with batch automation

Screw Feeder



- Feeder and agitator for a continuous or batch feeding with an accuracy < at 3%

Page 4

Belt / Vibrating Feeder



- Continuous or batch dosing for accurate dosing of fragile products

Page 16

Butterfly Valve



- Butterfly valve with pneumatic actuator for an absolute sealing and with electric regulation (4-20 mA)

Page 42

Slide Gate Valve



- Slide gate valve with no flow restriction when fully opened even with poorly flowing material

Page 46

Rotary Airlocks



- Rotary valve for a continuous feeding process and for a totally sealed pressure between the downstream and upstream machines

Page 19

Rotary Valve



- Rotary valve specially designed for sanitary dosing applications

Page 40

Pinch Valve



- Pinch valve, controlled pneumatically, adapted to be installed inline into pneumatic pipeline

Page 50

Automation



- Valves and feeders control is managed by the Pal' Touch® technology which is configured by PALAMATIC PROCESS automation engineers

Page 53

SCREW FEEDERS

PALAMATIC PROCESS has designed a range of industrial feeders suitable for all your application requirements. With our expertise, we offer you precise dosing equipment, for high, regular or low throughputs, depending on the type of your bulk products.

Screw Feeder



Volumetric Feeder

Volumetric

Capacity: 24 to 6,458 L/h.
Objectives: dosing of any kind of bulk materials

The PALAMATIC PROCESS volumetric screw feeders offer a uniform, constant and controlled feeding of your powders held in a hopper. Thanks to the exchangeable screw design system, our feeders can handle a wide variety of materials with a gentle and precise feeding of free-flowing materials.

VOLUMETRIC FEEDER



The volumetric feeder provides accurate feeding of a wide variety of bulk products. The dosing of ingredients is conducted through a dosing screw which conveys the volume of material to feed. The rotation speed can be handled by a frequency inverter. The feeding precision is about 7 to 8%.

WEIGHT FEEDER



The weight feeder enables an automatic feeding of powdery or bulk materials by batch or in continuous process. The feeders are placed on a stable frame with a very efficient weighing system. This system works in gain-in-weight or loss-in-weight mode and provides a metering accuracy of 1%.



Models	D10	D11	D12	D13
Flow rates*	24 to 142 L/h.	89 to 523 L/h.	261 to 1,438 L/h.	1 174 to 6,458 L/h.
Tube ext. Ø in mm	33.7	42.4	76.1	114.3

*Frequency range: 45 to 100 Hertz



Dosing assembly
loss-in-weight

Dosing assembly
weight gain

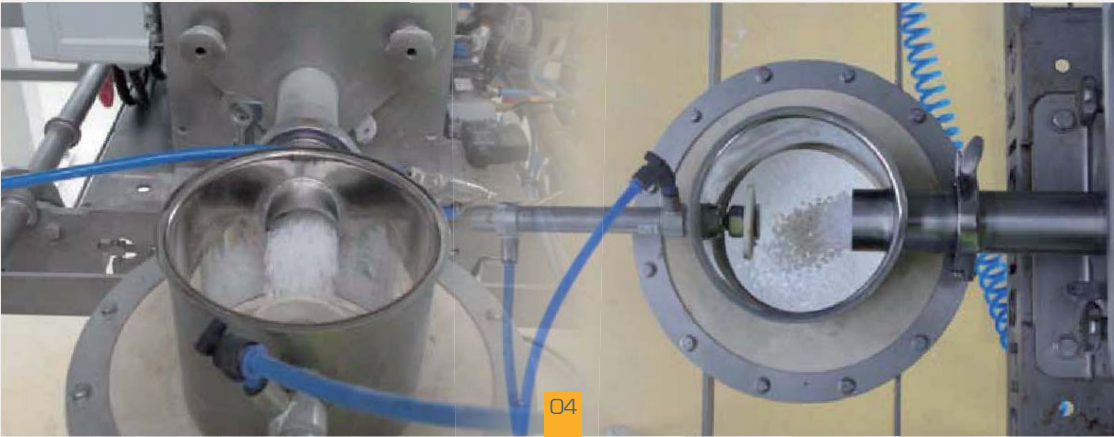

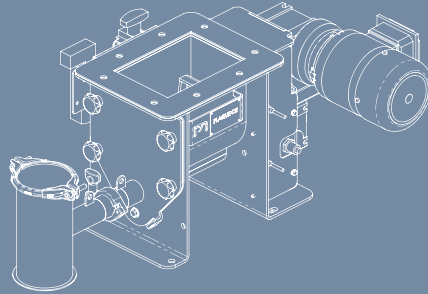

▶ **Hygienic design:** allows an easy access to all parts of the feeder to clean, control and disinfect



▶ **No mechanical friction** on the handled material

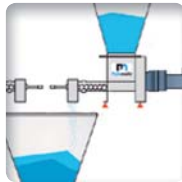

▶ **High linear feed**



▶ **Agitator** ensuring a constant feeding volume

Advantages



▶ COMPLETE SCREWS RANGE

- Pigtail



Round section spiral without centre pipe

Light materials, granular products, PVC, pellets, polymers in pellets.

- Ribbon



Ribbon spiral on pipe

Heavy sticky materials, heavy oxides, clays.

- With shaft



Standard screw

Heavy fluid materials, metallic grains.

▶ AGITATORS RANGE



▶ The agitator rotates constantly or intermittently at adjustable frequency. This intermittent operation allows an effective feeding of delicate, friable products which might bridge unless gently and regularly activated.

▶ PNEUMATIC GATE



▶ The pneumatic gate stops the product flow and averts the raise of humidity level.

▶ FEEDER D10 (size and capacity)

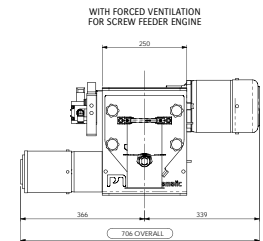
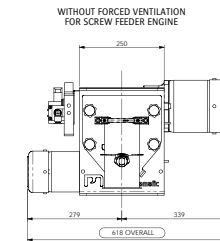
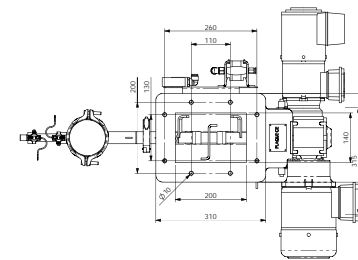
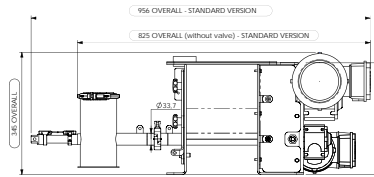

Feeder screws	Application	Gear ratios	Rotation speed	Theoretical throughput	Precision*
Type		1/...	rev./min.	l./h.	g.
Pigtail	Light sticky materials: flour, sugar, cocoa, pellets, granular products, light and slightly sticky oxides	10	138	142	5 g
		15 (Standard)	92	95	
		20	69	71	
		28	49	51	
Ribbon	Light materials, granular materials, pellets, PVC, polymers in pellets	40	35	35	3 g
		10	138	103	
		15 (Standard)	92	69	
		20	69	51	
With shaft	Heavy fluid materials, metallic granules	28	49	37	1 g
		40	35	25	
		10	138	97	
		15 (Standard)	92	64	
		20	69	48	
		28	49	34	
		40	35	24	

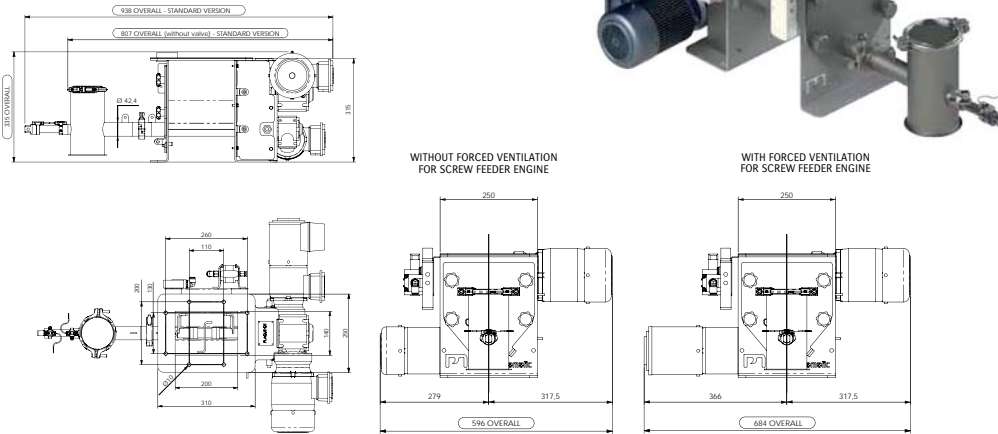

*Accuracy: The accuracy provided for a batch operating system with a metering device fitted with a pneumatic quick-closing valve. Flow control is provided by a PALAMATIC PROCESS automated system integrating the management of large and small fall velocities. Accuracy may vary depending on the "quality of implementation of the dosing or weighing hopper" (inequality of the structure and electronic grade).

FEEDER D11 (size and capacity)



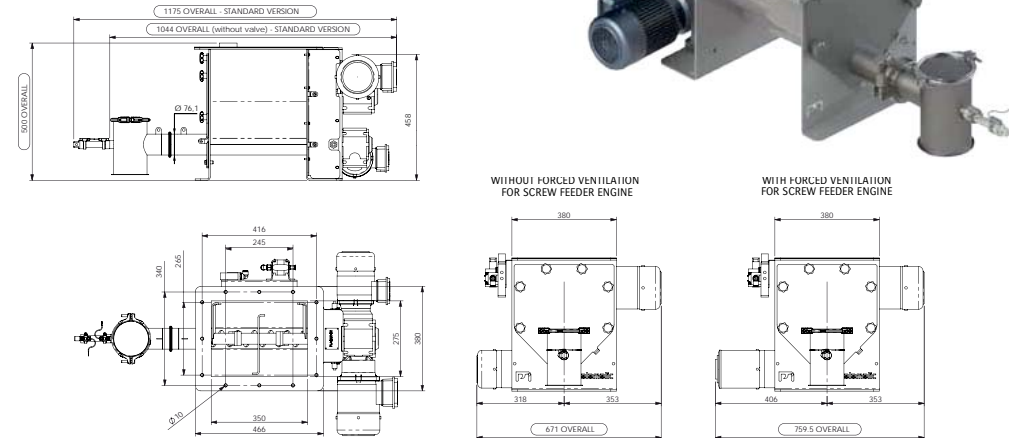

FEEDER D12 (size and capacity)



Feeder screws	Application	Gear ratios	Rotation speed	Theoretical throughput	Precision*
Type		1/...	rev./min.	L/h.	g.
 Pigtail	Light sticky materials: flour, sugar, cocoa, pellets, granular products, light and slightly sticky oxides	10	138	523	5 g
		15 (Standard)	92	348	
		20	69	261	
		28	49	186	
		40	35	130	
 Ribbon	Light materials, granular materials, pellets, PVC, polymers in pellets	10	138	380	3 g
		15 (Standard)	92	253	
		20	69	190	
		28	49	135	
		40	35	95	
 With shaft	Heavy fluid materials, metallic granules	10	138	356	1 g
		15 (Standard)	92	237	
		20	69	178	
		28	49	127	
		40	35	89	

*Accuracy: The accuracy provided for a batch operating system with a metering device fitted with a pneumatic quick-closing valve. Flow control is provided by a PALAMATIC PROCESS automated system integrating the management of large and small fall velocities. Accuracy may vary depending on the "quality of implementation of the dosing or weighing hopper" (inequality of the structure and electronic grade).

Feeder screws	Application	Gear ratios	Rotation speed	Theoretical throughput	Precision*
Type		1/...	rev./min.	L/h.	g.
 Pigtail	Light sticky materials: flour, sugar, cocoa, pellets, granular products, light and slightly sticky oxides	10	138	1,438	10 g
		15 (Standard)	92	959	
		20	69	719	
		28	49	513	
		40	35	359	
 Ribbon	Light materials, granular materials, pellets, PVC, polymers in pellets	10	138	1,046	5 g
		15 (Standard)	92	697	
		20	69	523	
		28	49	373	
		40	35	261	
 With shaft	Heavy fluid materials, metallic granules	10	138	1,273	1 g
		15 (Standard)	92	848	
		20	69	636	
		28	49	454	
		40	35	318	

*Accuracy: The accuracy provided for a batch operating system with a metering device fitted with a pneumatic quick-closing valve. Flow control is provided by a PALAMATIC PROCESS automated system integrating the management of large and small fall velocities. Accuracy may vary depending on the "quality of implementation of the dosing or weighing hopper" (inequality of the structure and electronic grade).

FEEDER D13 (size and capacity)

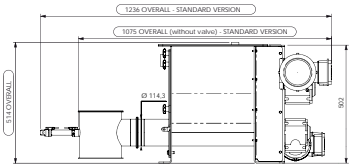

WITHOUT FORCED VENTILATION FOR SCREW FEEDER ENGINE

WITH FORCED VENTILATION FOR SCREW FEEDER ENGINE

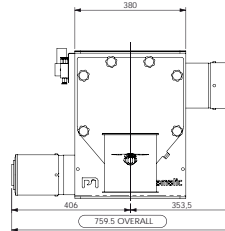
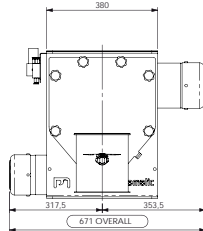
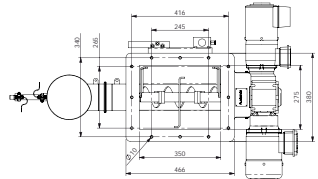

Feeder screws	Application	Gear ratios	Rotation speed	Theoretical throughput	Precision*
Type		1/...	rev./min.	L./h.	g.
 Pigtail	Light sticky materials: flour, sugar, cocoa, pellets, granular products, light and slightly sticky oxides	10	138	6,458	20 g
		15 (Standard)	92	4,305	
		20	69	3,229	
		28	49	2,306	
		40	35	1,614	
 Ribbon	Light materials, granular materials, pellets, PVC, polymers in pellets	10	138	4,696	15 g
		15 (Standard)	92	3,131	
		20	69	2,348	
		28	49	1,677	
		40	35	1,174	
 With shaft	Heavy fluid materials, metallic granules	10	138	5,029	10 g
		15 (Standard)	92	3,353	
		20	69	2,514	
		28	49	1,796	
		40	35	1,257	

*Accuracy: The accuracy provided for a batch operating system with a metering device fitted with a pneumatic quick-closing valve. Flow control is provided by a PALAMATIC PROCESS automated system integrating the management of large and small fall velocities. Accuracy may vary depending on the "quality of implementation of the dosing or weighing hopper" (inequality of the structure and electronic grade).

IMPACT OF PARTICULE SIZE

Material references	Floor (Type 55)	Sugar (cristal n°2)	Plastic granules
Granulometry in μm	100 μm	500 - 700 μm	2 - 5 mm
Product family	Fine	Crystal	Granules
Correction factor (feeding rate of the screw)	1.31	0.96	0.91

CALCULATION EXAMPLE OF RATES FOR CALCIUM CARBONATE

Customer data

Product to be metered	Calcium carbonate
Bulk density	0.7
Granulometry	70 μm
Product family	Fine
Type of coil	Screw with whaft
Correction factor	1.31
Wished actual flow rate	155 L/h.

Calculation formula

$$\text{Theoretical throughput} = \frac{\text{Actual flow rate}}{\text{Correction factor}} = \frac{155}{1.31} = 118 \text{ L/h.}$$

Result

Type of feeder	D11
Motor reducing ratio	1/28
Theoretical throughput	127 L/h.*

*See flow charts of the feeders

MASS FLOW RATES GRAPH WITH D11 FEEDER (PIGTAIL TYPE SCREW) BASED ON THE 3 FAMILIES

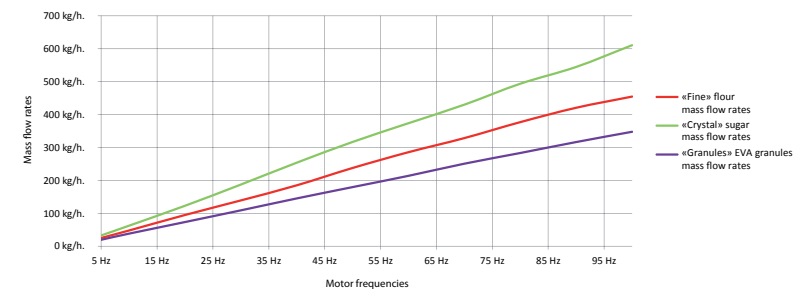

Screw Feeder

Weighing System



Capacity: 24 to 6,458 L/h.
Objectives: controlled feeding of materials

The batch feeding system guarantees an accurate weighing for each batch (granule or powder). The batch weighing provides a homogeneous and complete control of the product flows, a better accuracy and contributes to processing efficiencies.

TECHNICAL SPECIFICATIONS

Parts in contact with the material: stainless steel 304 L/316 L
Structure and bolts: stainless steel 304 L/316 L
Finishes of flange extremity: stainless steel 304 L/316 L
Base capacity: 50 to 65 litres



Homogenization tool

Feeding rotor

Load cells to ensure a constant weight

Dosing screw

Pneumatic closing valve of the filling tube

There is three types of weight feeders:

- **Weight feeder in loss-in-weight:** it provides the fastest and most accurate measurement and control of individual ingredients fed into a batch process
- **Gain-in-weight batching:** downstream the feeder, it doses and controls the weighing
- **Continuous weight feeder:** the feeder enables a continuous feeding by regulating its speed depending on the feeder loss weight to get a constant flow rate



▶ **Load cells:** system of three load cells to control the quantity of introduced powder

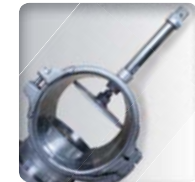

▶ **Closing membrane** to cut off the product flow and avoid raise of humidity



▶ **Motor** dedicated to drive the dosing system

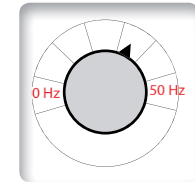

▶ **Inverter** to adjust through-puts

Advantages



The feeders D10, D11 D12 and D13 PALAMATIC PROCESS are compatible with the installation of servo load cells.

Models	D10	D11	D12	D13
Tube ext. Ø in mm	33.7	42.4	76.1	114.3

Dosing accuracy < to 1%

Options



Sealed flexible connection without weighing interference



Local weighing display for direct information

▶ RAPID DISASSEMBLY (STANDARD)

Design allowing rapid disassembly of the feeder to facilitate cleaning phases. The standard design enables dismantling and provides easy access to all parts to perform the manual cleaning.

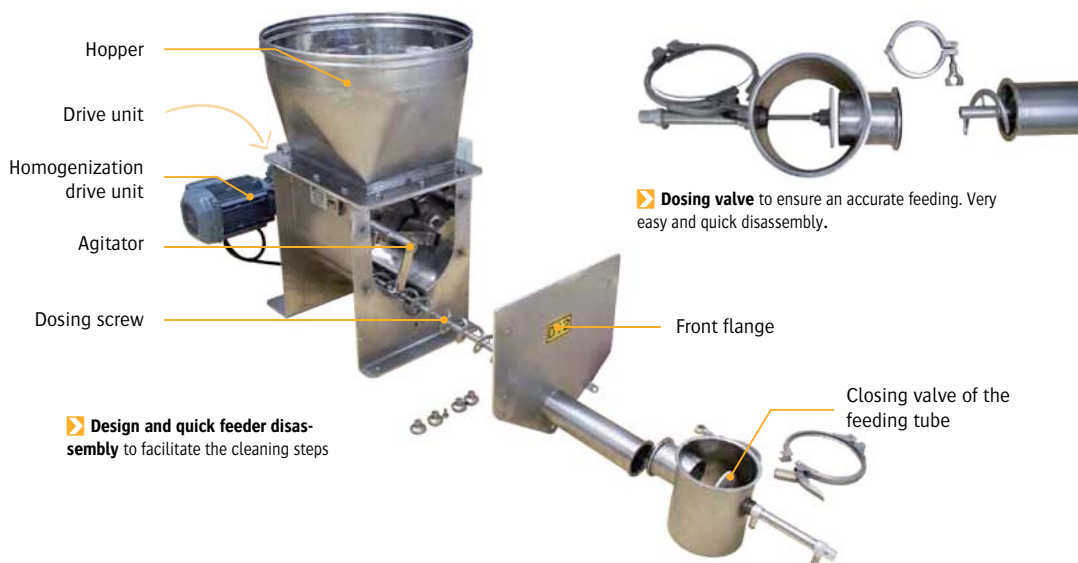

Mirror polished finishes that can be integrated for applications in food and cosmetics areas.



▶ EASYCLEAN VERSION

Some applications require frequent cleaning of the feeder either for changes of materials and/or due to constraints of allergens, pigments, etc... To respond to this industrial issue and in the context of offering sanitary equipment, PALAMATIC PROCESS developed the Easyclean option on its entire range of dosing. This Easyclean option enables quick dismantling of all parts of the dispenser without any use of tools and without supporting loads. This is guaranteed by the integration of rails and rollers on the flanges of the feeder.

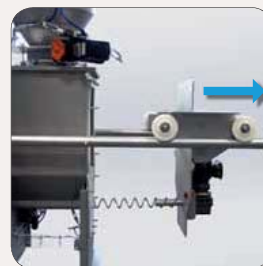
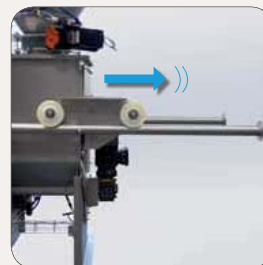

Belt Feeder

Capacity: up to 5 t./hr.
Objectives : extraction and weighing

PALAMATIC PROCESS belt feeder were specially designed for product continuous dosing/weighing. They are particularly suitable for such sectors as cement, steel, minerals, fertilizer production and food industry.

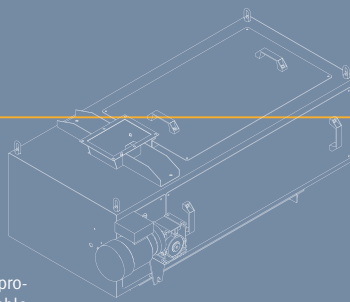

USE

Belt feeders capture the mass of material that passes over a measuring path. The timing control adjusts the belt speed to ensure the desired flow. They operate with a constant belt speed. The product weight is entered when passing on the belt.

TECHNICAL SPECIFICATIONS

Rates: the rates range varies by a factor of 1 to 10.
 The nominal flow rate depends directly on three factors:

- Bandwidth
- Belt speed
- Layer thickness

The layer thickness is controlled by an adjustable deflector at the outlet of the feeding hopper.

OPERATING MODE

Continuous weighing: the standard application for belt feeders is continuous dosing.

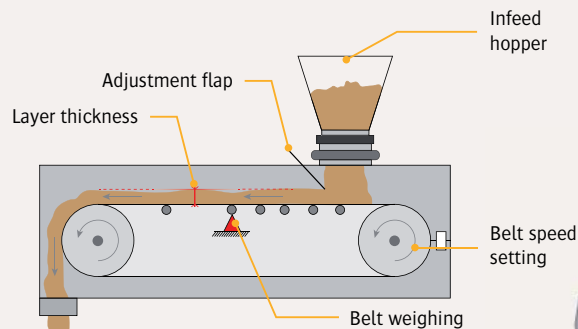

[+] Advantages

- Gentle Handling of materials
- High flexibility in terms of dosing
- Easy cleaning and maintenance
- Accuracy +/- 0.5%

Vibrating Feeder



Capacity: up to 2 t./hr.
Objectives : extraction and weighing

PALAMATIC PROCESS vibrating feeders allow dosing of fragile ingredients and abrasive materials. Installed on load cells, vibrating feeder is used for loss-in-weight dosing.

Belt Feeder
Vibrating Feeder

USE

The vibrating feeders consist of a vibrating base with the product flow trough. The flow rates and accuracy can be adjusted to complement the dimensioning of the trough. Flow rates: depending on the dimensions of the trough, the product layer thickness is adjusted by the adjustment flap positioned at the hopper outlet.

TECHNICAL SPECIFICATIONS

- . Dosing principle: gravimetric (loss-in-weight metering) or volumetric
- . Dosage device: vibrating trough
- . 3 widths: 80 to 250 mm.
- . Fabrication feeding hopper and vibrating trough manufacturing: steel, stainless steel
- . Volume of the feeding hopper: custom-made - possibility of flow aid
- . Rectangular or tubular extraction
- . Possibility of powdering with output enlargement

EXAMPLES OF IMPLEMENTATIONS



➤ Vibrating feeder skid



➤ Setting of the vibration amplitude (flow management)



➤ Gap for conditioning



➤ Vibrating feeder with integrated metal detection for capsules

[+] Advantages

- Product Distribution metered over a significant width
- Fast and effective cleaning

EXAMPLES OF IMPLEMENTATIONS

Industrial Feeders



▶ Cleaning products



▶ Printing industry



▶ Stationery



▶ Petfood



▶ Environmental technologies

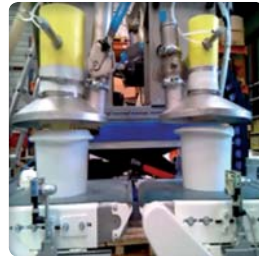

▶ Hygiene products and industrial water treatment

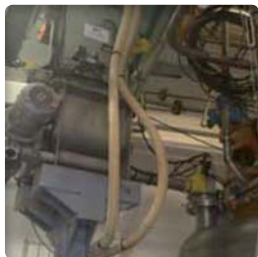

▶ Insecticides



▶ Discover our feeding equipment in video on our YouTube channel: www.youtube.com/user/Palamaticprocess

500
+ de **500** installations
of feeding equipment in
FRANCE and **ABROAD**

ROTARY AIRLOCK VALVES



The main function of a rotary airlock valve is to regulate the flow from one chamber to another while maintaining a good airlock condition. The material handled is usually dry free flowing powder, dust or granules. The rotary airlock valves are mainly used in the dust filtration field, the pneumatic conveying industry, for the pressure differentials or to control the rotor-stator gap.

▶ DROP THROUGH ROTARY AIRLOCK FEEDER



The drop through rotary airlock feeder are designed to feed and discharge in a controlled way powdery or granular products coming from silos, hoppers, pneumatic conveying installations, bag filters houses, cyclones. This rotary valve is adapted when a high throughput is required. The effective flow rates are very variable depending on the products flowing.

▶ BLOW THROUGH ROTARY AIRLOCK FEEDER



The blow through rotary feeder has been designed to feed and convey bulk products (powders and granules) in numerous applications. When the material tends to clog, this airlock valve is the ideal solution.

▶ ROTARY AIRLOCK FEEDER FOR WOOD PELLETS AND CHIPPINGS



This rotary airlock valve feeds and discharges, in a controlled way, wood pellets and chippings from silos, hoppers, pneumatic conveying installations, bag filter houses, cyclones.

▶ DUST ROTARY AIRLOCK FEEDER



The dust rotary airlock feeder is specially dedicated for a combined use with cyclo-separators for silos, hoppers, dust filters, dust cyclones or even dosing systems. This rotary airlock feeder suits simple or undemanding industrial applications. Its main function is to be an airlock.

Rotary Airlock Feeder

Drop Through



Capacity: 2.2 to 19.5 litres/revolution
Objectives: material extraction and feeding

Rotary airlock valves are used for the dosing, feeding or discharging of fine-grained and powdered materials or granulates contained in silos, hoppers, pneumatic conveying installations, filters or even cyclones.

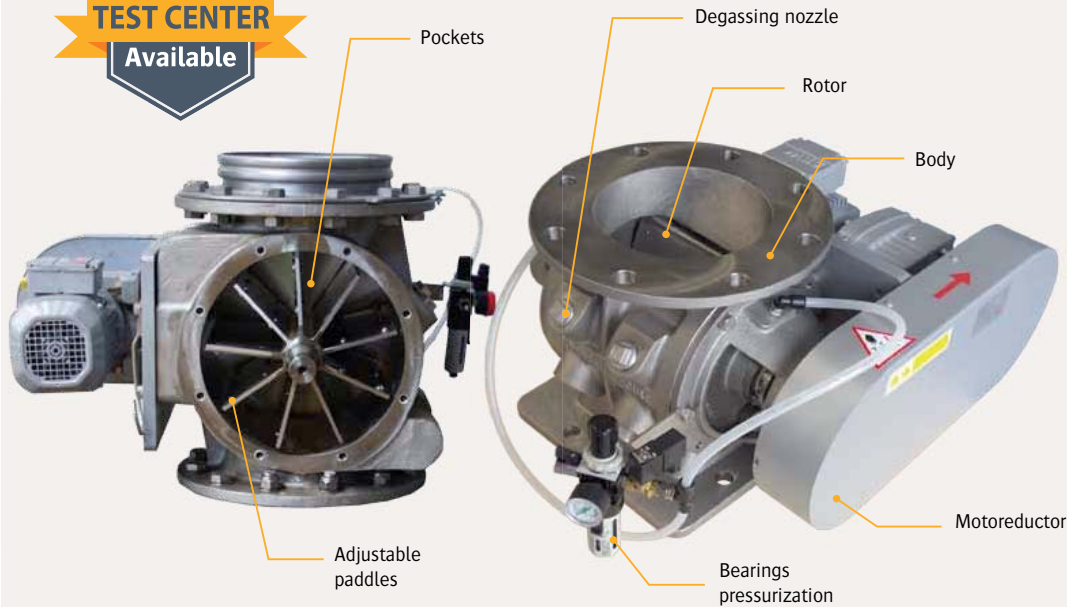

TECHNICAL SPECIFICATIONS

Manufacturing materials: cast iron body or stainless steel
Surface treatment of the rotor: nickel plating, teflon, hardened paddles
Motorisation: direct or chain sprocket
Rotor: steel or stainless steel
Fixed rotor speed: 10, 20, 30 revolutions/min.
Variable rotor speed: 4-35 revolutions/min.
Capacity: 2.2 to 19.5 L/t.



▶ **Easy access to internal mechanical parts** for a quick and simple cleaning



▶ **Compact and robust design**



▶ **ATEX version** to resist to explosions and flame flow



▶ **High feeding accuracy**

Advantages



▶ DROP THROUGH ROTARY VALVE RANGE



Models	150 ²	200 ²	250 ²	300 ²
Capacity (litres/rev.)	2.2	5.4	10.9	19.5
Flange section in mm.	150x150	200x200	250x250	300x300

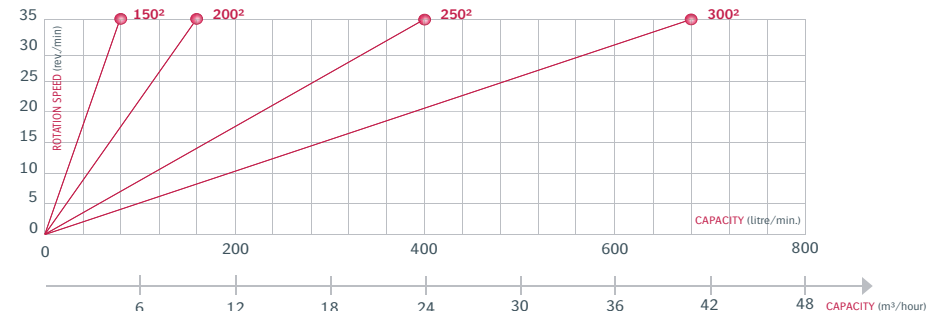

Drop Through Rotary Airlock Feeder

▶ DROP THROUGH ROTARY VALVE - 150²

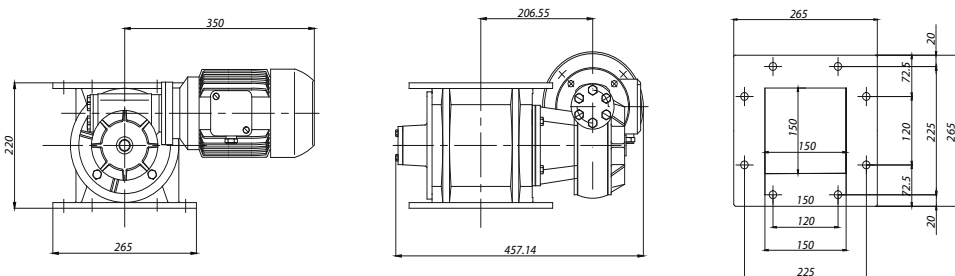

10 rounds/min.					20 rounds/min.					30 rounds/min.				
Flow rate m ³ /h.	Load factor *	Power KW	Torque **	Weight (kg)	Flow rate m ³ /h.	Load factor *	Power KW	Torque **	Weight (kg)	Flow rate m ³ /h.	Load factor *	Power KW	Torque **	Weight (kg)
1.1	0.85	0.37	190	73	1.98	0.75	0.5	155	58	2.6	0.65	0.5	110	58

* For medium to easy flowing product
** For a load factor of 100%

▶ DROP THROUGH ROTARY VALVE - 250²

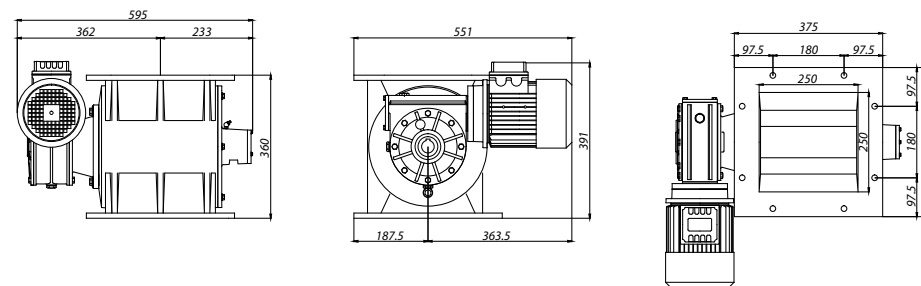

10 rounds/min.					20 rounds/min.					30 rounds/min.				
Flow rate m ³ /h.	Load factor *	Power KW	Torque **	Weight (kg)	Flow rate m ³ /h.	Load factor *	Power KW	Torque **	Weight (kg)	Flow rate m ³ /h.	Load factor *	Power KW	Torque **	Weight (kg)
5.6	0.85	0.5	300	140	9.81	0.75	0.75	250	123	12.8	0.65	1.1	240	123

* For medium to easy flowing product
** For a load factor of 100%

▶ DROP THROUGH ROTARY VALVE - 200²

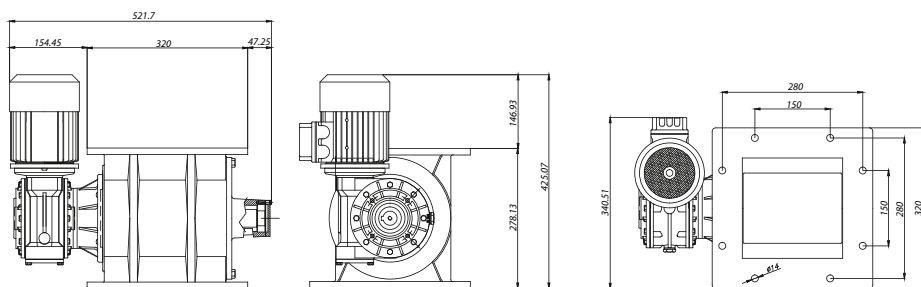

10 rounds/min.					20 rounds/min.					30 rounds/min.				
Flow rate m ³ /h.	Load factor *	Power KW	Torque **	Weight (kg)	Flow rate m ³ /h.	Load factor *	Power KW	Torque **	Weight (kg)	Flow rate m ³ /h.	Load factor *	Power KW	Torque **	Weight (kg)
2.8	0.85	0.37	190	88	4.86	0.75	0.5	155	73	6.3	0.65	0.75	150	73

* For medium to easy flowing product
** For a load factor of 100%

▶ DROP THROUGH ROTARY VALVE - 300²

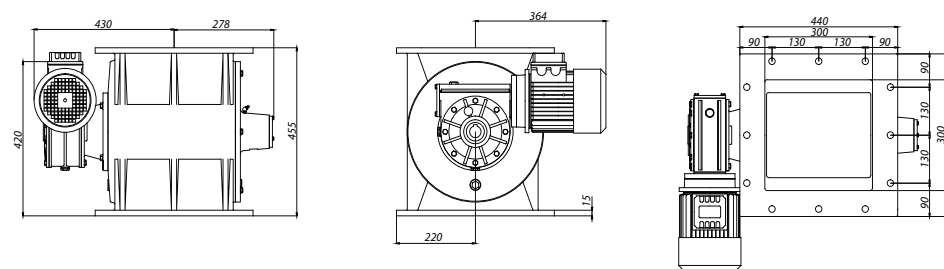

10 rounds/min.					20 rounds/min.					30 rounds/min.				
Flow rate m ³ /h.	Load factor *	Power KW	Torque **	Weight (kg)	Flow rate m ³ /h.	Load factor *	Power KW	Torque **	Weight (kg)	Flow rate m ³ /h.	Load factor *	Power KW	Torque **	Weight (kg)
9.9	0.85	0.75	400	195	17.6	0.75	1.1	360	181	22.8	0.65	1.5	300	181

* For medium to easy flowing product
** For a load factor of 100%

Drop Through Rotary Airlock Feeder

▶ EXAMPLES OF INDUSTRIAL APPLICATIONS

▶ Application under hopper

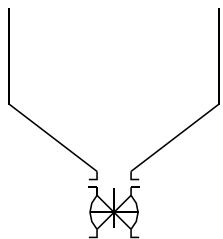

▶ Application under silo

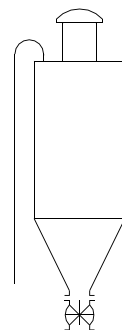

▶ Application under cyclone to separate material flow/conveying air

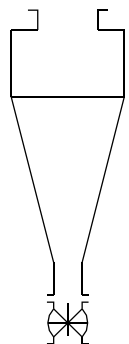

▶ Application under the pneumatic conveying feeding system to load the material into the piping

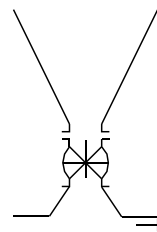

▶ Application under filter to insure the sealing and evacuation of fine particles

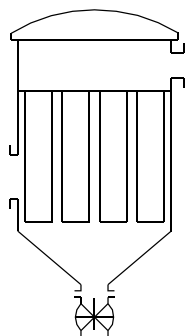

▶ Application above the filling stations to dose the product

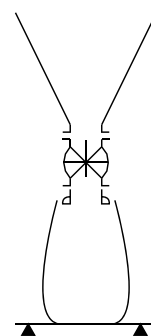

Rotary Airlock Feeder

Blow Through



Capacity: 5 to 38 litres/revolution
Objectives: powders dosing to feed the pneumatic conveying

The blow through adaptor enables to meter and/or feed material from a hopper or a bin into a pneumatic conveying line and to restrict or prevent conveying air from blowing up into the hopper or bin.

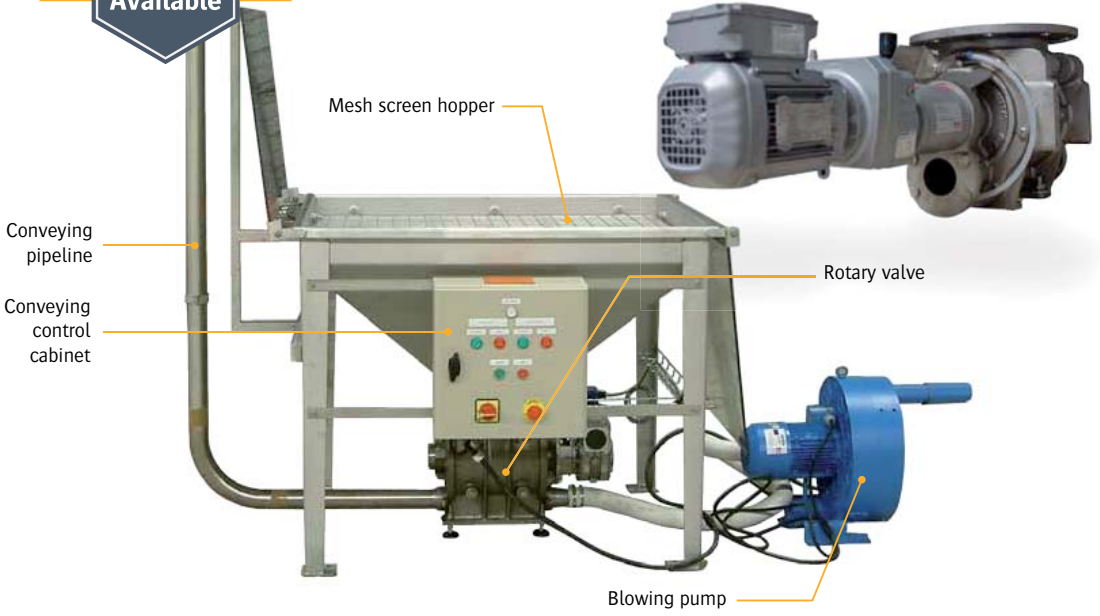

TECHNICAL SPECIFICATIONS

- Manufacturing materials:** cast iron body or stainless steel
- Surface treatment of the rotor:** nickel plating, tefloning, hardened vanes
- Motorisation:** direct or chain sprocket
- Rotor:** steel or stainless steel
- Fixed rotor speed:** 10, 20, 30 revolutions/min.
- Variable rotor speed:** 4-35 revolutions/min.
- Capacity:** 2.2 to 19.5 L/t.



▶ **Surface treatment of the rotor:** chromium and nickel plating, tefloning



▶ **Motorisations:** direct by gear, coaxial variator with chain transmission or without motorisation (bare shaft)



▶ **Cast iron body** or stainless steel AISI 304 L/316 L



▶ **ATEX version** for a high explosion resistance and at the passage of flame



BLOW THROUGH ROTARY VALVE RANGE

Models	ERL 05	ERL 10	ERL 15	ERL 20	ERL 35
Capacity (litres/rev.)	5	9	14	20	38
Feeding flange in mm.	170 x 122	135 x 238	148 x 276	196 x 337	284 x 569
Differential pressure max.	0.7	0.7	0.7	0.7	0.7
Service temperature	-20°C-60°C	-20°C-60°C	-20°C-60°C	-20°C-60°C	-20°C-60°C

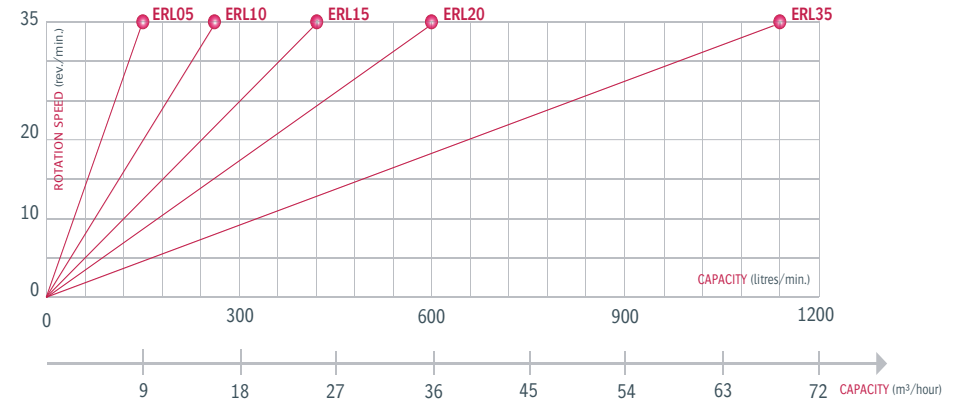

Blow Through Rotary Airlock Feeder

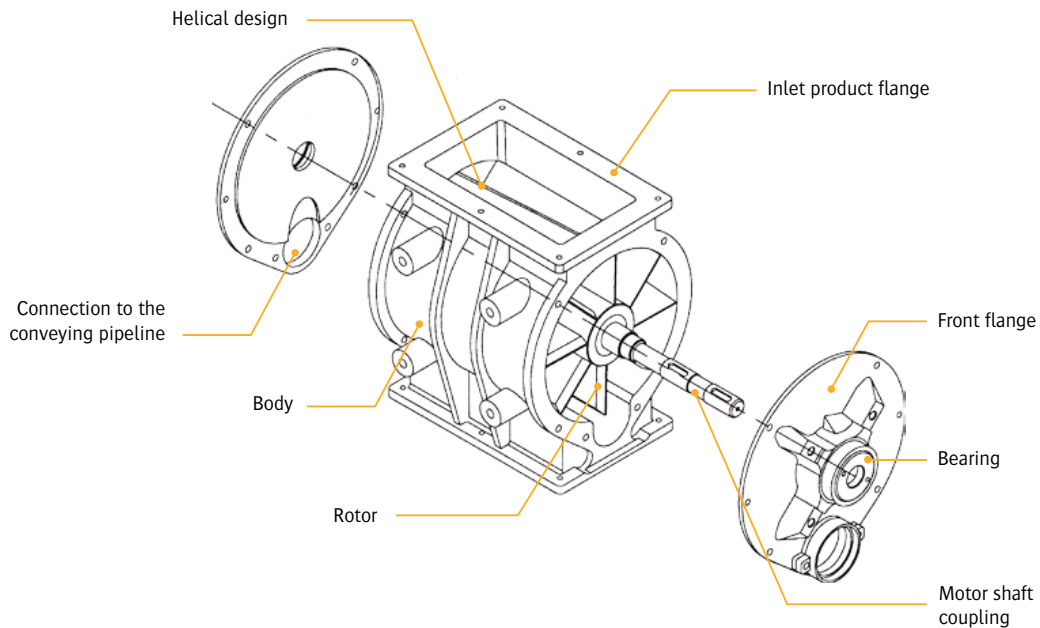

▶ BLOW THROUGH ROTARY VALVE - ERL 10

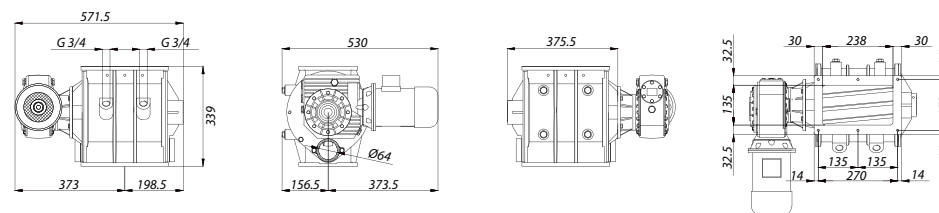

10 rounds/min.				20 rounds/min.				30 rounds/min.			
Flow rate m ³ /h.	Load factor *	Power KW	Torque (Nm)**	Flow rate m ³ /h.	Load factor *	Power KW	Torque (Nm) **	Flow rate m ³ /h.	Load factor *	Power KW	Torque (Nm) **
5.4	0.85	0.37	300	10.8	0.75	0.55	232	16.2	0.65	0.55	149

* For medium to easy flowing product
** For a load factor of 100%

▶ BLOW THROUGH ROTARY VALVE - ERL 05

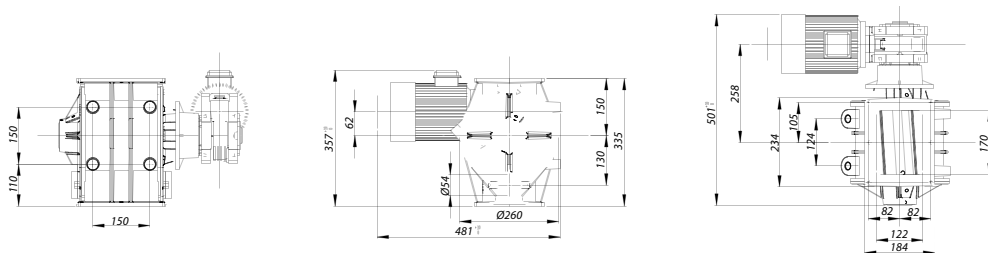

10 rounds/min.				20 rounds/min.				30 rounds/min.			
Flow rate m ³ /h.	Load factor *	Power KW	Torque (Nm)**	Flow rate m ³ /h.	Load factor *	Power KW	Torque (Nm) **	Flow rate m ³ /h.	Load factor *	Power KW	Torque (Nm) **
3	0.85	0.37	300	6	0.75	0.55	232	9	0.65	0.55	149

* For medium to easy flowing product
** For a load factor of 100%

▶ BLOW THROUGH ROTARY VALVE - ERL 15

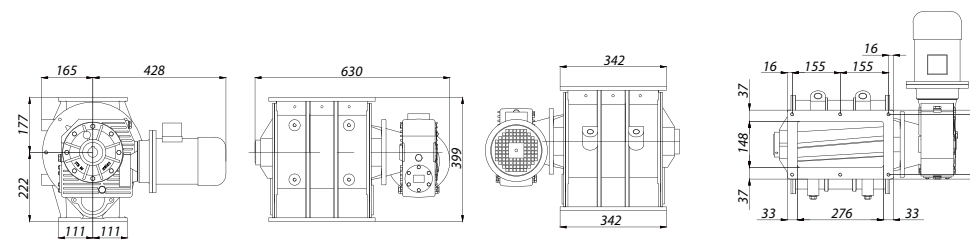

10 rounds/min.				20 rounds/min.				30 rounds/min.			
Flow rate m ³ /h.	Load factor *	Power KW	Torque (Nm)**	Flow rate m ³ /h.	Load factor *	Power KW	Torque (Nm) **	Flow rate m ³ /h.	Load factor *	Power KW	Torque (Nm) **
8.4	0.85	0.55	472	16.8	0.75	0.75	328	25.2	0.65	1.1	308

* For medium to easy flowing product
** For a load factor of 100%

Blow Through Rotary Airlock Feeder

▶ BLOW THROUGH ROTARY VALVE - ERL 20

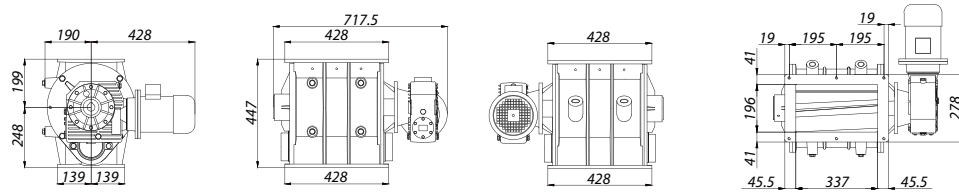

10 rounds/min.				20 rounds/min.				30 rounds/min.			
Flow rate m ³ /h.	Load factor *	Power KW	Torque (Nm)**	Flow rate m ³ /h.	Load factor *	Power KW	Torque (Nm)**	Flow rate m ³ /h.	Load factor *	Power KW	Torque (Nm)**
12	0.85	0.55	472	24	0.75	1.1	328	36	0.65	1.1	308

* For medium to easy flowing product
** For a load factor of 100%

▶ BLOW THROUGH ROTARY VALVE - ERL 35

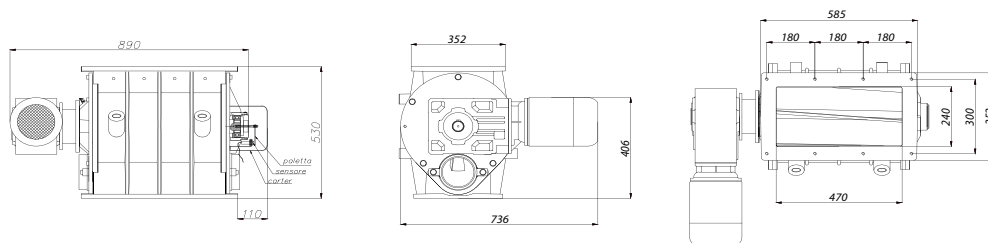

10 rounds/min.				20 rounds/min.				30 rounds/min.			
Flow rate m ³ /h.	Load factor *	Power KW	Torque (Nm)**	Flow rate m ³ /h.	Load factor *	Power KW	Torque (Nm)**	Flow rate m ³ /h.	Load factor *	Power KW	Torque (Nm)**
22.8	0.85	1.1	929	45.6	0.75	1.5	633	68.4	0.65	2.2	630

* For medium to easy flowing product
** For a load factor of 100%

▶ USE

The blow through rotary airlock feeders are designed to suit to pneumatic conveying processes. They can be mounted inline into a pneumatic conveying line.



Due to the space available under the production machines, the blow through rotary airlock feeders are an efficient solution. The added value of those rotary valves is to transfer sticky materials. The air conveying flow, through the rotary valve, ensures the cleaning of the rotor by taking off particles stuck on the walls.

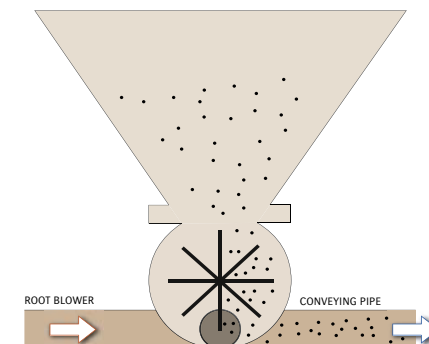



▶ DEFLECTOR FOR GRANULES

The design highly respects the granular materials.

- High degree of filling
- Large degassing nozzle
- Strong design
- Available with direct motorisation or by chain
- Drilled flanges according to PN10, ANSI 150 lbs and JIS
- Versions compliant with ATEX 94/9/CE are available



▶ EASYCLEAN ROTARY VALVE

For a sanitary using in the food and pharmaceutical industries.

The rotary valve gets a rotor which can be easily dismantled in few minutes for controlling and cleaning the inside parts. The extraction mechanism of the moving parts is more secured for the operator and offers a better flexibility for the cleaning and maintenance of the installation between various productions. These stainless steel rotary valves can be dismantled easily as well as keeping the highest standards of hygiene.



▶ PRESSURIZED BEARINGS

To seal the rotary valve.

An air flow is injected to avoid that fine particles come inside the sealing system through the cable gland.



▶ ADJUSTABLE PADDLES

Adjustment of the rotor vane depending on the properties of each material.

A standard rotor is composed by 8 fixed vanes. Nevertheless, it is possible to configure the rotors, for making rotary valves suitable for the material, by adjusting vanes.

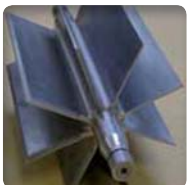

▶ MANUFACTURING MATERIAL

Manufacturing material adapted to your needs and expectations.

Three different configurations are available: steel design, stainless steel body and cast iron flange or even the full cast iron design. The aluminium configuration is anodised.



▶ DEGASSING NOZZLE

Deaeration system of the body to avoid the pressure return.

The degassing chambers are specially designed for being used in pneumatic conveying systems. It permits to avoid the pressure return into the piping and the hopper from where the product is extracted.

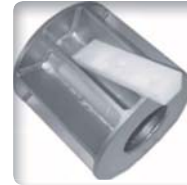

▶ PRECISION SHIM

For a more accurate feeding and the maintaining of a high rotation speed.

The precision shims are fixed directly onto the rotor and reduce the rotary airlock valve displacement by a fine feeding or the maintaining of high rotation speed.



▶ SPEED SET BOX

To facilitate the material introduction in the conveying pipeline.

The speed set box is settled under the rotary airlock valve to introduce the material in the pneumatic conveying pipeline.



▶ OVERFILL CONTROLLER

To ensure a rotary airlock valve with large displacement.

The overflow controller has been specially designed for revolving materials or for applications needing a rotary airlock valve with large displacement.



▶ DEGASSING BOX

To evacuate the air.

The degassing box is designed for pneumatic conveying applications to ensure the blower air evacuation returning by the rotary airlock valve.

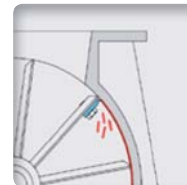

▶ ROTOR WITH SCRAPER PADDLES

To eliminate sticky materials from the rotary airlock valve body.

The rotor with scraper vanes helps to get a very strong sealing and a full cleaning of the rotary airlock valve body for very sticky materials.

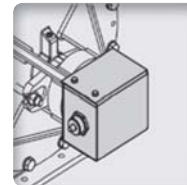

▶ ROTATION SENSOR

The box indicates a number of rotor rotations.

The box is an indicator aimed to check the airlock valve rotation speed and to identify any problems in case the velocity is too low.

Rotary Valve

Wood Pellets and Chippings



Capacity: 2.2 to 19.5 litres/revolution
Objective: woods pellets and chippings dosing

PALAMATIC PROCESS rotary valves are the perfect solution for controlled discharging and feeding of wood pellets or chippings from silos, hoppers, pneumatic conveying systems, bag filter houses, or cyclones.

TECHNICAL SPECIFICATIONS

Service temperature with special version: -20 - 150 °C

Rotor: wear resistant steel HARDOX

Certifications: the rotary valves are designed for wood combustible industry and are in conformity with ONORM M7132, ONORM M7133, ONORM M7135, ONORM M7136, ONORM M7137



Rotors equipped with blades



Robust compact design for a longer lifetime



Direct motorisation

Advantages

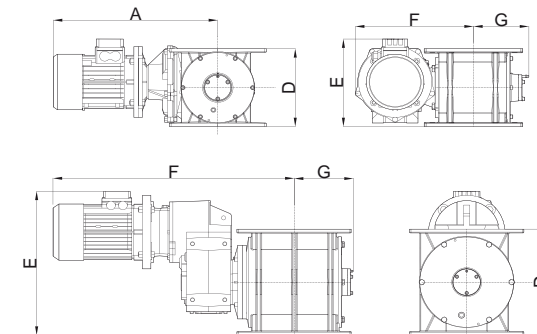
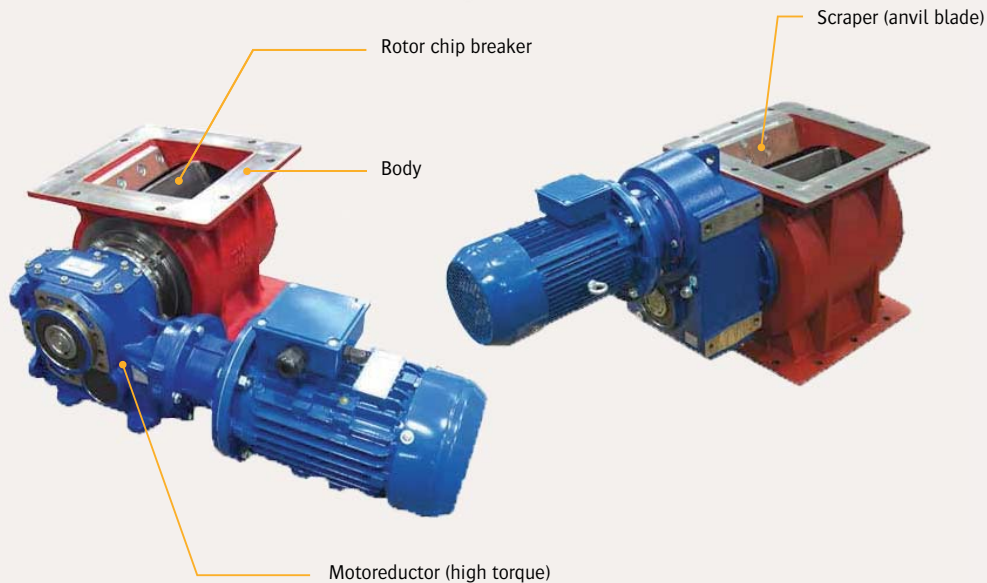

Models	A*	D	E*	F*	G	Motor speed (rpm)	Motor Power (kW)	Dosing flow rate (L/t.)
RWN 02	500	220	248	325	131	20	0.75	2.2
						30	1.1	
RWN 05	540	280	237	340	162	20	1.1	5.4
						30	1.5	
RWN 10	-	360	490	792	188	20	1.5	10.9
						30	2.2	
RWN 20	-	455	561	855	226	20	2.2	19.5
						30	3.0	

Rotary Valve

Dust Collection



Capacity: 6 to 8.5 liters/revolution
Objectives: regulate and dose the conveyed materials

The PALAMATIC PROCESS dust lock valve has a dedicated design for filter applications. The standard inlet and outlet flanges are drilled in conformity with PN10 and are suitable for both round and square counter flanges. This rotary valve is suitable for simple and undemanding industrial applications, where its main function is to be an airlock.

TECHNICAL SPECIFICATIONS

Certifications: ATEX certified rotary valve for Zone 20 indoor and Zone 2 and 21 outdoor
Resistant: a pressure up to 10 bars
 ATEX 95 type for explosive atmospheres
Flange connection: DN200/250 (round/square)
Capacity: 6 to 8.5 liters per revolution
Pressure: differential pressure 0.5 bar
Shape of flanges: round or square, compliant with PN10/ DIN2576

OPERATING MODE

The rotary airlock valve has a large opening for the performance of the rotor with 6 flexible vanes made of polyurethane and which are adjustable and interchangeable.
 The standard rotary airlock valve is adapted to materials handling the temperature up to 70°C and a maximum pressure difference of 0.5 bar.
 The stators of those rotary airlock valves have been tested at a hydraulic pressure of 20 bars, which is the equivalent of the resistance to the internal shocks of 10 bars.

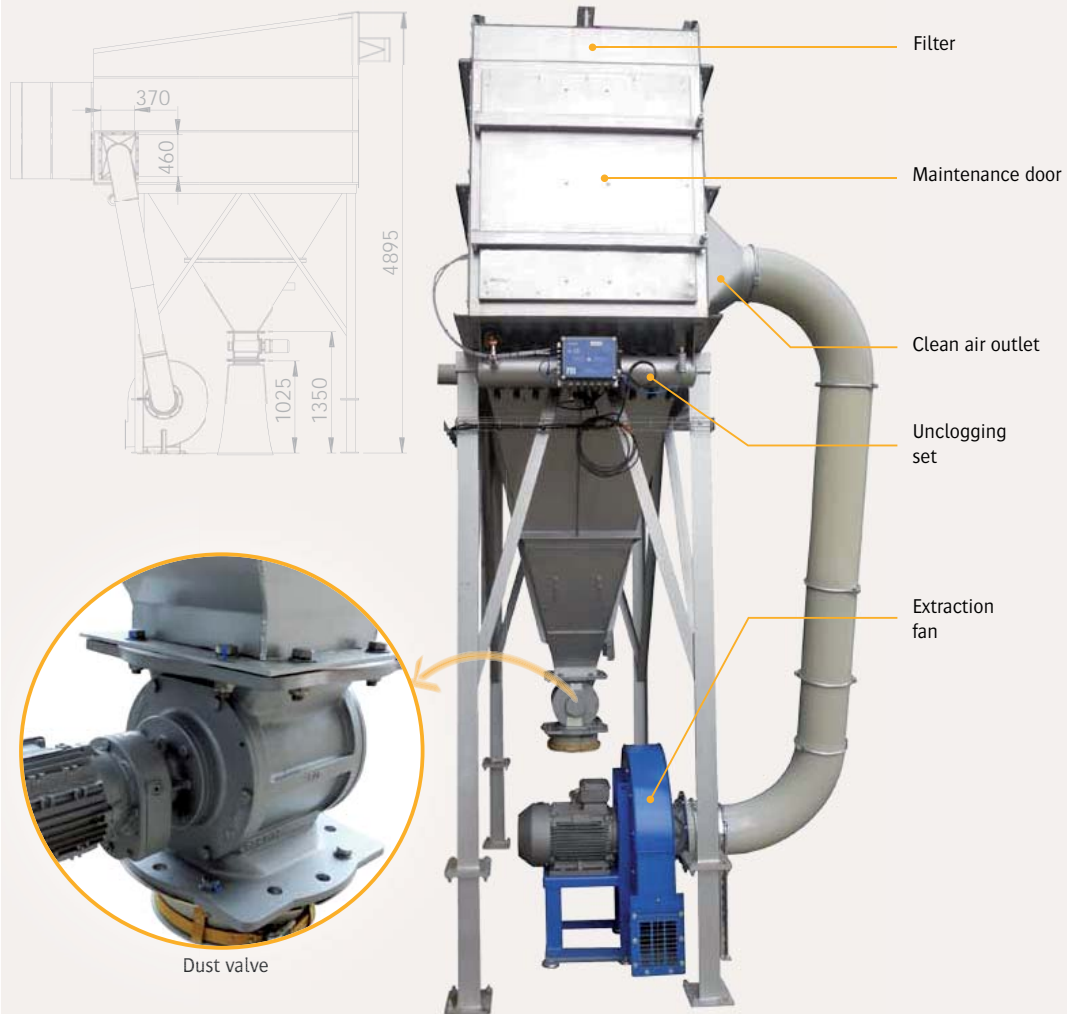

Minimal air leakage



Flame proof certification ATEX 20-21-22



Flexible paddles manufactured in polyurethane



Standard flanges to make them suitable for PN10 round or square flanges

Advantages

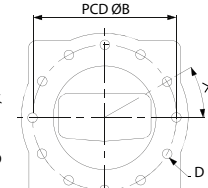
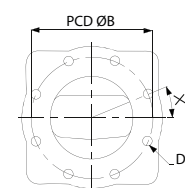
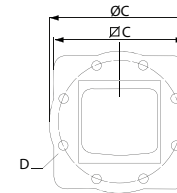
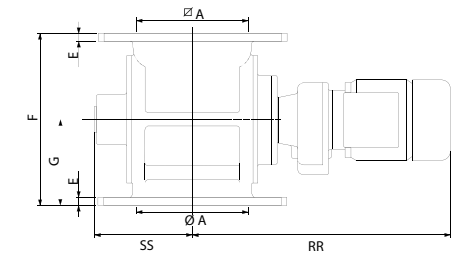

Models	Litres / Tour	Inlet & Outlet	A	ØA	ØB	ØC	C	D	E	F	G	X	RR	SS
ERD 200	6	200	200	200	295	340	320	8xØ23	14	310	155	22,5°	465	176
ERD 250	8.5	250	250	250	350	406	370	12xØ23	15	325	162.5	30°	485	196

EXAMPLES OF IMPLEMENTATIONS

Rotary Valves



Under silo, salt



Under cyclone, resin transfer



Under hopper, food ingredients



Under a dust collector



Feeding a pneumatic conveying pipeline



Pharmaceutical products



Food product



Feeding for the conditioning



Discover our rotary valves in video on our YouTube channel:
www.youtube.com/user/Palamaticprocess

INDUSTRIAL VALVES



PALAMATIC PROCESS offers a complete range of industrial valves to easily control the feeding and the fluid volume. Our valves guarantee an accurate sealing (under silo, hoppers, mechanical and pneumatical conveyors, weighing system, etc.) of the free-flowing powdery products or liquids in several sectors such as food, chemical, pharmaceutical, cosmetic or even building industries.

BUTTERFLY VALVE - MODEL VPP



The butterfly valve is a system which moves the spade by rotation around a perpendicular axis perpendicular to the direction of flow and, in open position, is bypassed by the fluid. Its use is perfect for non-viscous liquids. The butterfly valve is used in automatic or manual installations with stainless steel. This equipment limits the loss-in-weight and offers a constant product flow rate.

ROTARY VALVE - MODEL VRP



The rotary valve has been designed to respect rigorous sanitary requirements and to be disassembled quickly by the operator. The rotary valves are suitable for pharmaceutical applications to cut off or control the products flow. They offer a continuous powders and granulates feeding as well as a uniform dosing.

SLIDE GATE VALVE - MODEL VGP

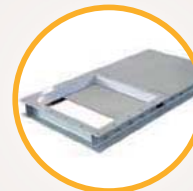

The slide gate is one of the most effective ways to close a flow path in a material handling line. The slide gate valve is designed for a complete or relative seal and its control is perfectly linear.

PINCH VALVE - MODEL VMP



The pinch valve fits perfectly with conveying application by ensuring the regulation and dosing of powdery products without any loss of pressure. This pinch valve enables the free flowing of the material. The oval shape of the valve body guarantees an efficient and quick closing of the valve. The pinch valves are ideal to stop powders, grains, fibers and dense mixtures flow.

Rotary Valve



Diameter: DN 100 to 250
Objectives: discharging, sealing and closing

The rotary valve has been designed to respect rigorous sanitary requirements and enables a quick disassembly by the operator. The rotary valves are particularly suitable for pharmaceutical industries to stop or control the products flow. These valves guarantee a continuous powders and granulates feeding as well as an uniform dosing.

TECHNICAL SPECIFICATIONS

Distribution: DN 100 to 250
Finishes: stainless steel 316L
Actuator: pneumatic until 6 bars



▶ For a constant dosing and a flow control



▶ Double solution with full open disc and small rotary valve DN50 or 80

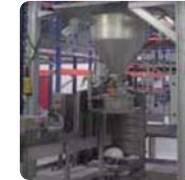

▶ Implementation on a sacks conditioning skid



▶ Tri-clamp flange for a quick mounting and removal of the valve

Advantages



The rotary valve has been designed to cut off and control the free-flowing products in pharmaceutical industries. They enable a continuous feeding of powders and granulates with a uniform dosing.

The valve is composed of two elements. The butterfly is adapted to execute a coarse dosing while the little rotor performs more accurate dosing. The maximum accuracy achievable is around ± 20 grams. The valve can be combined with dosing or weighing systems.

This double valve can be supplied with a rubber seal between the paddles and the rotor to make it suitable for applications where the pressure rises to 0.5 bar.

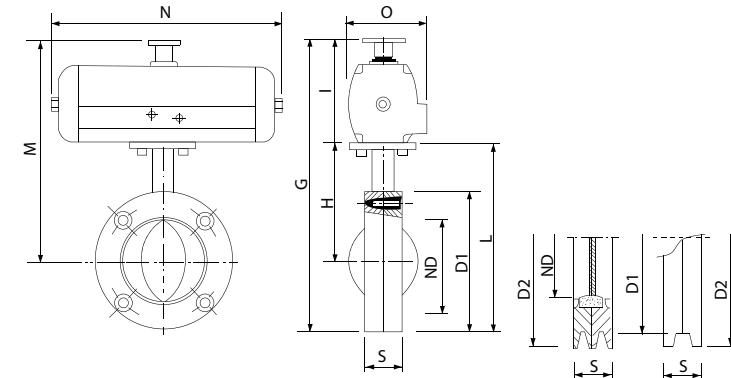

Models	D1	D2	S	G	H	I	L	M	N	O
DN 100	150	180	38	298	130	93	205	223	250	80
DN 150	200	230	38	348	155	93	255	248	250	80
DN 200	250	280	38	398	180	93	305	273	250	80
DN 250	306	330	40	488	213	122	366	335	310	105



Butterfly Valve



Manual, Pneumatic Actuator, Motoreductor

Objectives: discharge, sealing and closing

The butterfly valves are used to close tanks, hoppers and silos containing powder or granular materials. The butterfly valves are used in every installations needing to stop the materials flowing displaced by gravity or by pneumatic conveying.

TECHNICAL SPECIFICATIONS

Manufacturing: cast iron or stainless steel
Diameter: DN 100 to 400



▶ **Shaft for actuator:** manual; pneumatic; electric; option positioner 4-20 mA

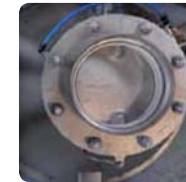

▶ **Sealed closing at 6, 10, 16 bar**



▶ **Profiled valve** for an optimized material flow



▶ **Flange connection PN or tri clamp** for pharmaceutical applications

Advantages

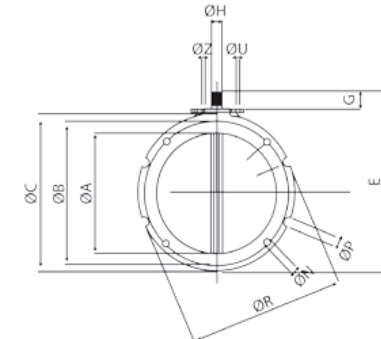
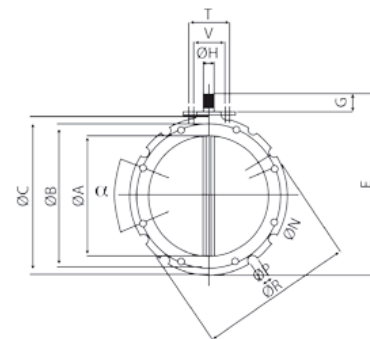

Models	ØA	ØB	ØC	ØD	E	F	G	ØH	N (holes)	P (honings)	ØR	α	S	T	U	V	Z	Kg
VPP 100	95	180	220	105	250	115	35	22x19	N°4xØ14	N°4xØ20	220	22°30'	40	80	M12	50	M10	4
VPP 150	150	200	228	163	290	115	35	22x19	N°4xØ14	N°4xØ14	228	22°30'	40	80	M12	50	M10	5
VPP 200	200	250	278	213	340	115	35	22x19	N°4xØ14	N°4xØ14	278	22°30'	40	80	M12	50	M10	6.5
VPP 250	250	300	328	236	390	115	35	22x19	N°8xØ14	N°8xØ20	325	11°15'	40	80	M12	50	M10	7.5
VPP 300	300	350	378	313	440	115	35	22x19	N°8xØ14	N°16xØ20	375	5°41'	40	80	M12	50	M10	9
VPP 350	350	400	440	363	530	123	50	28x25	N°8xØ14	N°8xØ20	440	10°	40	80	M12	-	M10	16
VPP 400	400	470	530	413	580	123	50	28x25	N°8xØ14	N°16xØ20	530	4°30'	40	80	M12	-	M10	20.5

Options



Manual lever

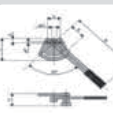

Interchangeable actuators

▶ PNEUMATIC ACTUATOR

Motorized pneumatic valve operating mode:

- **Double acting:** a pneumatic cylinder, piston rack type, drives the valve shaft with a 1/4 turn movement. A distributor sends a pneumatic signal alternatively in one of the two cylinder chambers to open or close the valve.
- **Single acting:** the pneumatic cylinder is equipped with piston compression springs. The pneumatic signal executes only one of the two movements of opening and closing, the second one being operated by the springs pressure. This type of operating mode helps to provide a safety position in case of power failure.

▶ OPTION OF REINFORCED SEALING - Inflatable seat

Some applications need significant sealing action under vacuum or pressure. The inflatable seat technology ensures this result.

The PALAMATIC PROCESS butterfly valves use air pressure to expand the seal against the discs, providing an even-distribution for a bubble tight seal. Since the seat makes only causal contact with the disc during valve opening and closing, there is minimal disc impingement. This is unlike conventional butterfly valves where disc impingement leads to shaving of the seat which decreases operational performance. This option increases the valve life and its efficiency.



▶ OPTION OF POSITIONER TO FEED BY CONTROL SIGNAL 4-20 mA

The pneumatic actuator is set up with a controller for 4-20 mA which adjusts the opening angle of the butterfly. This technology feeds the material and regulates the flow.

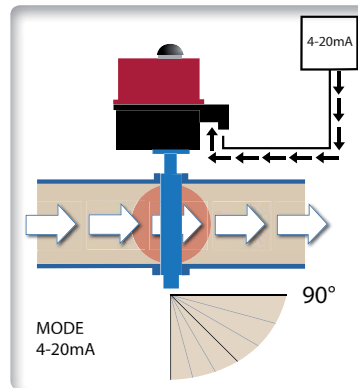

▶ RESISTANCE TO CLEANING AGENTS

The design highly respects granular products.

The butterfly valves are resistant to aggressive cleaning agents and other chemical products.

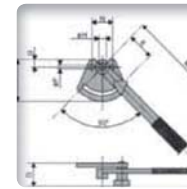

▶ EXCHANGABLE ACTUATORS

For a sanitary using in food and pharmaceutical industries.

There are a variety of actuators by which the valve can be operated: manual, electric, single or double acting pneumatic actuator.



▶ HIGH TEMPERATURE RESISTANCE

Operating temperature up to 205°C.



▶ BFM FLEXIBLE CONNECTION

The quality of the stainless steel (316 L) and the valve disc enable food and pharmaceutical applications. EPDM, viton, rubber.



▶ FLANGE CONNECTION

Valve conception with flange.

Tri-clamp system for applications where the valve dismantling is important for the cleaning operations.

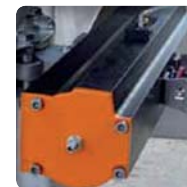

▶ 4-20 mA

Dosing specificity.

Slide Gate Valve



Handwheel or Pneumatic

Objectives: extraction and dosing by gravity

The slide gate valves are commonly used to control flows with suspended solids. These valves are designed to shut off the bulk flow product thanks to the central blade seal which provides an excellent product retention. Our slide gate valves are mainly used in the chemical, food, energy or even water treatment industries.

TECHNICAL SPECIFICATIONS

- Diameter:** DN 80 - DN 800
- Flanges finishes:** EN 1092 PN 10
- Sealing:** ISO 5208, classe A
- Temperature:** maximum 180°C (depending on the pressure, the liquid and the materials)
- Manufacturing:** stainless steel 304 L & 316 L
- Actuator:** hand wheel, ratchet lever, chain wheel, manual wheel reductor, pneumatic cylinder, electric servomotor, hydraulic cylinder
- Pressure:** 10 bars (DN 80-DN 350)/6 bars (DN 400-DN 600)/4 bars (DN 700-DN800)

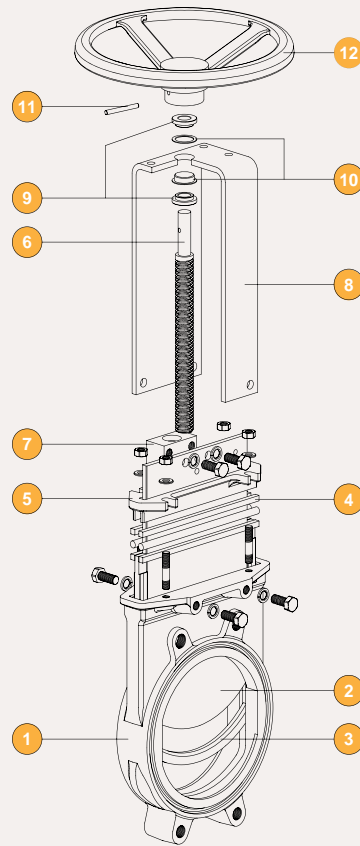

- 1 Body
- 2 Spade
- 3 Rubber seal
- 4 Trim
- 5 Cable gland
- 6 Stem
- 7 Drive nut
- 8 Arch
- 9 Brass bush
- 10 Nylon bush and washer
- 11 Pin
- 12 Hand wheel



➤ **Secured sealing** without any additional measurement thanks to the rubbers seal integrated in the polymere coating



➤ The valves bodies are totally coated with engineering polymer composite (food, FDA/EN approved on demand)



➤ **Exchangeable actuators:** manual, pneumatic or electromecanic



➤ **High resistance to abrasion**

Advantages



SQUARE SIZE VALVE

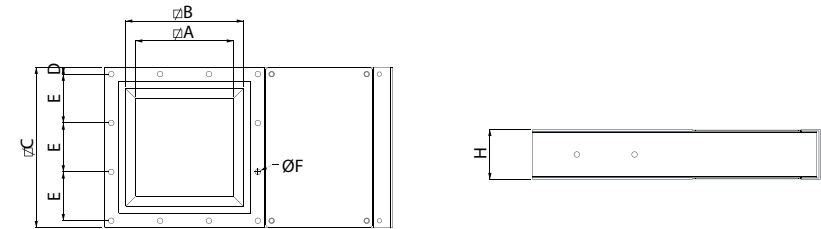

Models	Flow area AXA	B	C	D	E	N°E	ØF	Bolts	G	H	Kg
VGPC0150	120	175	261	15.5	115	2	12.5	M10	455	113	14
VGPC0200	170	225	311	15.5	93.3	3	12.5	M10	555	113	18
VGPC0250	220	275	361	15.5	110	3	12.5	M10	650	113	22
VGPC0300	270	325	431	23	128.3	3	12.5	M10	765	113	30
VGPC0350	320	375	481	18	89	5	12.5	M10	900	125	40
VGPC0400	370	425	531	15.5	100	5	12.5	M10	1 000	125	46

Dimensions in mm.



➤ **Manual: bi-directional knife gate valve** appropriate for products with a solids concentration and for bulk materials

➤ **Pneumatic: uni-directional knife gate valve** for liquids and solids

Slide Gate Valve

▶ ROUND SIZE VALVE

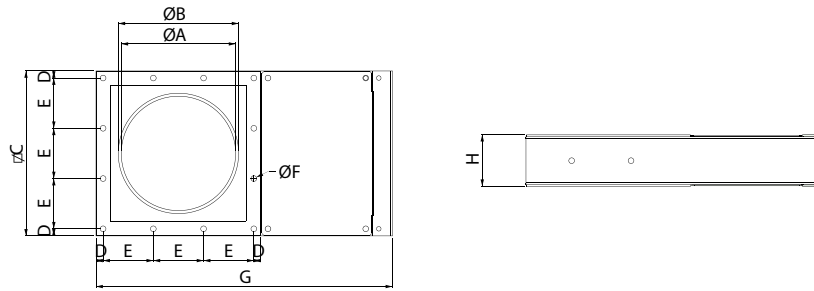

Models	Ø flow area A	ØB	ØC	D	E	N°E	ØF	Bolts	G	H	Kg
VGPRD0150	150	165	261	15.5	115	2	12.5	M10	455	113	14
VGPRD0200	200	215	311	15.5	93.3	3	12.5	M10	555	113	18
VGPRD0250	250	265	361	15.5	110	3	12.5	M10	650	113	22
VGPRD0300	300	315	431	23	128.3	3	12.5	M10	765	113	30
VGPRD0350	350	365	481	18	89	5	12.5	M10	900	125	40
VGPRD0400	400	415	531	15.5	100	5	12.5	M10	1,000	125	46

Dimensions in mm.

▶ RECTANGULAR SIZE VALVE

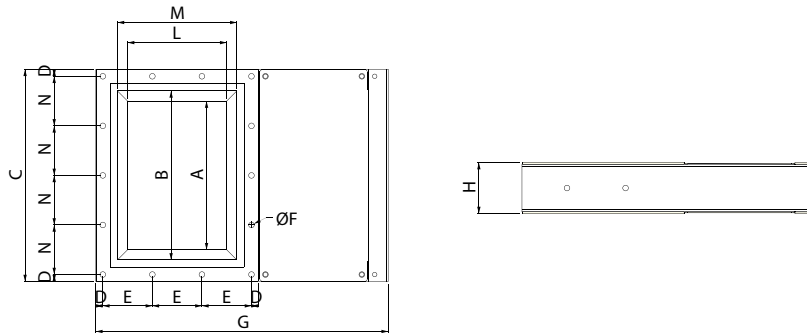

Models	A	B	C	D	E	N°E	ØF	Bolts	G	H	L	M	N	N°N	Kg
VGPR0150	204	260	346	15.5	115.0	2	12.5	M10	455	109	119	175	105	3	18
VGPR0200	281	337	423	15.5	93.3	3	12.5	M10	555	109	169	225	98	4	25
VGPR0250	353	409	495	15.5	110.0	3	12.5	M10	650	109	219	275	116	4	30
VGPR0300	428	484	592	23.0	128.3	3	12.5	M10	765	109	269	325	136	4	40

Dimensions in mm.

▶ SLIDE GATE VALVE WITH STANDARD FLANGE (for difficult applications)

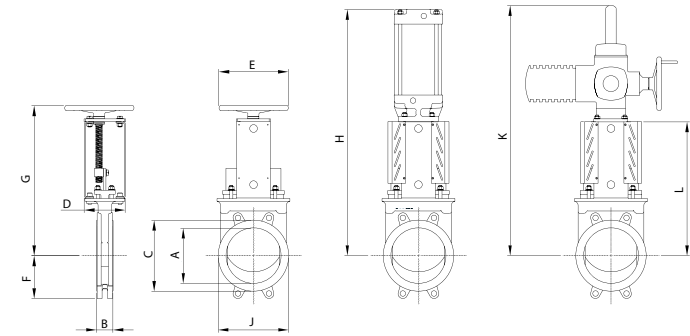

DN (mm.)	Size	A	B	C	D	E	F	G	H	J	K	L	Air feeding	Weight (kg)
50	1 ½	50	43	90	86	202	59	299	441	90	575	227	¼"	5.5
65	2 ½	65	46	105	86	202	66	324	481	105	600	252	¼"	6.5
80	3	80	46	120	86	202	88	346	519	120	623	275	¼"	7.5
100	4	100	52	144	86	202	101	381	574	144	658	310	¼"	9.5
125	5	125	56	169	86	250	112	421	709	169	698	350	¼"	12
150	6	150	56	192	86	250	130	464	776	192	740	392	¼"	14
200	8	200	60	256	151	317	154	561	888	256	818	483	½"	27
250	10	250	68	307	151	317	153	657	1,034	307	914	579	½"	38
300	12	300	78	354	151	317	213	753	1,180	354	1,059	675	½"	53
350	14	350	80	407	187	400	245	880	1,367	407	1,228	783	½"	81
400	16	400	80	460	187	400	246	977	1,514	460	1,375	880	½"	106
500	20	500	90	566	262	520	284	1,214	1,835	566	1,706	1,100	½"	185
600	24	600	100	682	262	520	341	1,419	2,311	682	2,011	1,305	1"	275

Dimensions in mm.

▶ FLANGE CONNECTION

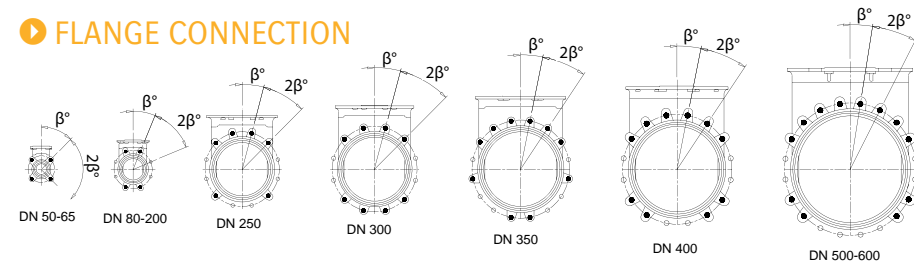

DN (mm.)	50	65	80	100	125	150	200	250	300	350	400	500	600
Ø external flange (mm.)	165	185	200	220	250	285	340	395	445	505	565	670	780
Ø bolts (mm.)	125	145	160	180	210	240	295	350	400	460	515	620	725
Front dimensions (mm.)	43	46	46	52	56	56	60	68	78	80	80	90	100
Number through-holes	-	-	4	4	4	4	4	6	4	6	6	8	8
Number tapped holes	4	4	4	4	4	4	4	6	8	10	10	12	12
Bolts size	M16	M16	M16	M16	M16	M20	M20	M20	M20	M20	M24	M24	M27
β°	45	45	22.5	22.5	22.5	22.5	15	15	11.25	11.25	9	9	9
Screw size (mm.)	14	16	10	12	12	14	16	18	18	18	20	24	24

Pinch Valve



12 models (Ø13 to Ø200)

FDA manufacturing

Objectives: complete shut off or flow control

The pinch valves provide the ability to control the flow of a fluid through an uninterrupted flow path for installation of pneumatic conveying. Economic, simple to implement and with low maintenance time, these pinch valves are the ideal solution for the passage of liquid, gas or powder materials by ensuring complete sealing of the tube when the pinch closes. Our pinch valves can be adapted at several applications: acids, bases (phosphates, soda, ammonia ...), viscous or abrasive liquids, food liquids or powders.

TECHNICAL SPECIFICATIONS

- Valve body manufacturing:** aluminum alloy
- Connection mouths manufacturing:** aluminum, hardened carbon steel or stainless steel 304 L/316 L
- Maximum operating pressure:** 3.5 bars
- Maximum inflation pressure :** 6.0 bars
- Maximum differential pressure:** 2.5 bars

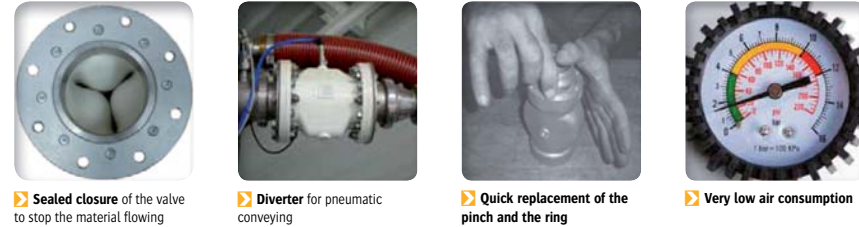
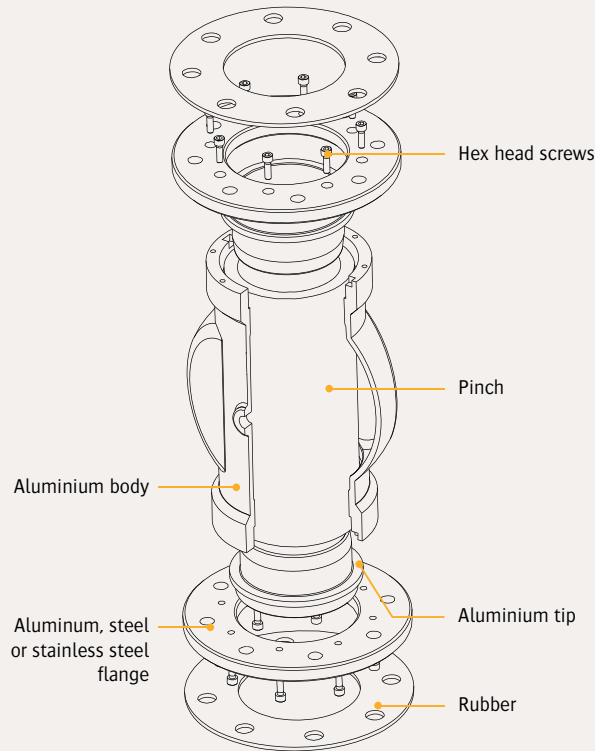
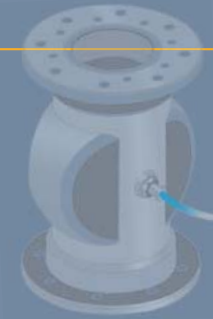

Advantages

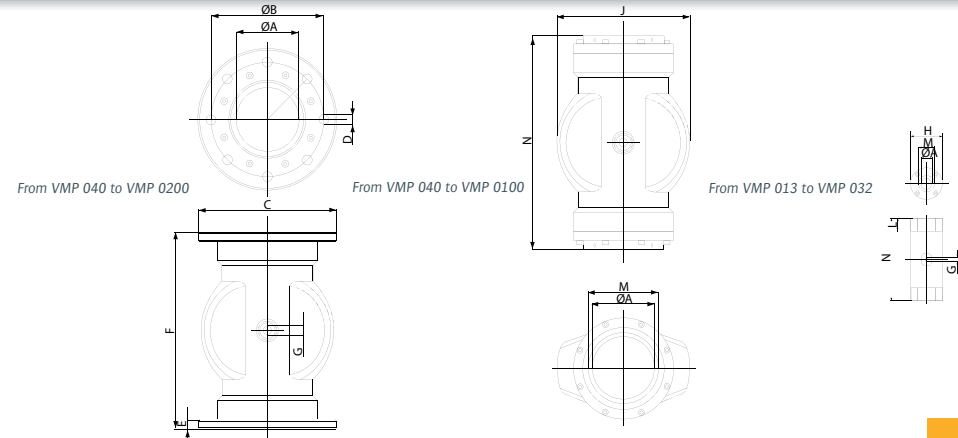

OPERATING MODE

The pinch valves are the solution for isolating and regulating abrasive, corrosive and fibrous products such as granulates, powder, etc.

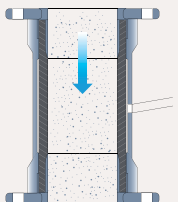

Position N°1 :
The valve is in open position. Its inner section is identical to the one of the piping.

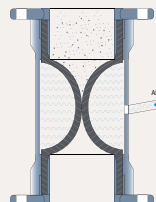

Position N°2 :
By introducing compressed air or pressurized water inside the body, the flexible sleeve bends to completely close the passage.

Models	A	B	C	D		E	F	G	H	J	L	M	N	Kg
				Diam.	No.									
VMP 013	13	-	-	-	-	-	-	1/8"	42	-	18	1/2"	120	0.40
VMP 020	20	-	-	-	-	-	-	1/8"	50	-	20	3/4"	130	0.50
VMP 025	25	-	-	-	-	-	-	1/8"	56	-	22	1"	130	0.70
VMP 032	32	-	-	-	-	-	-	1/8"	70	-	25	1+1/2"	165	1.10
VMP 040	40	110	150	M 16	4	12	178	1/8"	99	-	1+1/2"	202	2.20	
VMP 050	50	125	165	M 16	4	15	190	1/4"	-	120	-	2"	214	3.40
VMP 065	65	145	185	M 16	4	15	225	1/4"	-	138	-	2+1/2"	230	4.00
VMP 080	80	160	200	M 16	4	15	270	1/4"	-	180	-	3"	294	5.40
VMP 0100	100	180	220	M 16	4	15	310	1/4"	-	214	-	4"	334	7.60
VMP 0125	125	210	250	M 16	4	15	350	1/4"	-	250	-	-	-	10.20
VMP 0150	150	240	285	M 16	4	18	396	1/4"	-	285	-	-	-	15.60
VMP 0200	200	295	340	M 16	4	25	460	1/4"	-	374	-	-	-	22.80

Dimensions in mm.

Options



Available in version ATEX zone 22



Pinch

EXAMPLES OF REALIZATIONS

Valves



Pharmaceutical products



Building industry

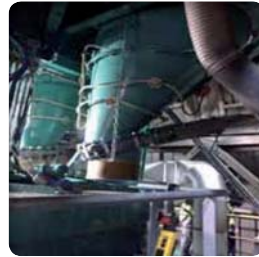

Waste treatment



Spices



Food products

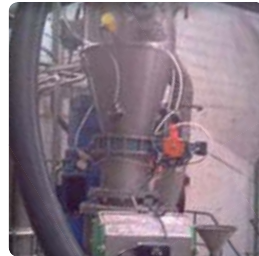

Chemical products



Pneumatic conveying



Cut off valve



Discover our feeding equipment in video on our YouTube channel: www.youtube.com/

AUTOMATION & ELECTRICITY



PAL'TOUCH[®] TECHNOLOGY

Designer of specific equipments, PALAMATIC PROCESS associates programmed PLCs with its production units in an ergonomic and visual way. The production control is as important as the result. That is why automation and IT engineers of PALAMATIC PROCESS review the raw material feeding, the batches traceability, operators identification and dosings database. Thanks to continuous exchanges during the phase of project execution, between your production team and our engineering office, screens for packaging lines control offer ergonomic and easy use with unique personalization.

Equipment and programs: Schneider, Siemens, Rockwell, Omron, Philips, In-touch, Pc Vue, VijeoDesigner, ...

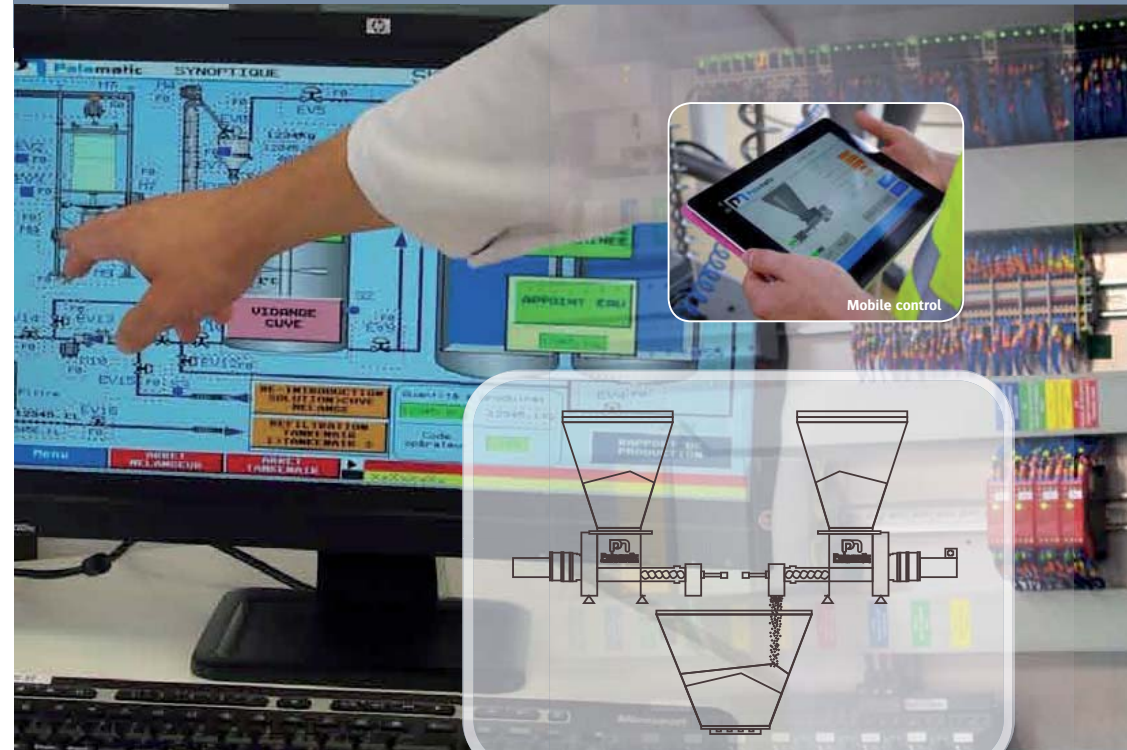

Our expertise:

FILLING SOLUTIONS FOR BIG BAG AND OCTABIN

To fill

EMPTYING SOLUTIONS FOR BIG BAG AND OCTABIN

To empty, compact and massage

SACK, DRUM AND CARDBOARD FILLING SOLUTIONS

To fill, package, handle

SACK AND DRUM EMPTYING SOLUTIONS

To empty, compact, handle, discharge

SOLUTIONS FOR PNEUMATIC CONVEYING

Vacuum, pressure

SOLUTIONS FOR MECHANICAL CONVEYING

To transfer with screw, belt conveyor, bucket elevator, aeromechanical or vibratory conveyor, truck loading spout

CRUMBLING AND GRINDING EQUIPMENT

To granulate, crumble, grind, pound, micronise, disagglomerate

SIFTING EQUIPMENT

To sift, segregate, sieve, protect

CONTAINERS AND STORAGE SOLUTIONS

To fill, charge, empty, contain

DOSING EQUIPMENT

To control, regulate, empty, extract

MIXING EQUIPMENT

To homogenise, incorporate, fluidify, stir, mix

FLOW AND CONNECTION

To vibrate, fluidise, unclog, drain, facilitate extraction, control the descent, prevent stacks and vaults, connect

INDUSTRIAL DUST COLLECTING EQUIPMENT

To filter, clean, confine, secure



Palamatic

PROCESS >>> machines • engineering

contact@palamatic.fr

Sales Department: +33 (0)2 22 93 63 08

ZA La Croix Rouge • 35530 Brécé • France

Tel: +33 (0)2 99 86 06 22 • Fax: +33 (0)2 99 86 08 10

SAS au capital de 331 822 euros • R.C.S. Rennes B 384 894 093 • APE 4669B • N° T.V.A. : FR 14 384 894 093