

# Rotary Valve

# Wood Pellets and Chippings



**Capacity:** 2.2 to 19.5 litres/revolution  
**Objective:** woods pellets and chippings dosing

PALAMATIC PROCESS rotary valves are the perfect solution for controlled discharging and feeding of wood pellets or chippings from silos, hoppers, pneumatic conveying systems, bag filter houses, or cyclones.

## TECHNICAL SPECIFICATIONS

**Service temperature with special version:** -20 - 150 °C

**Rotor:** wear resistant steel HARDOX

**Certifications:** the rotary valves are designed for wood combustible industry and are in conformity with ONORM M7132, ONORM M7133, ONORM M7135, ONORM M7136, ONORM M7137



Rotors equipped with blades



Robust compact design for a longer lifetime



Direct motorisation

## Advantages

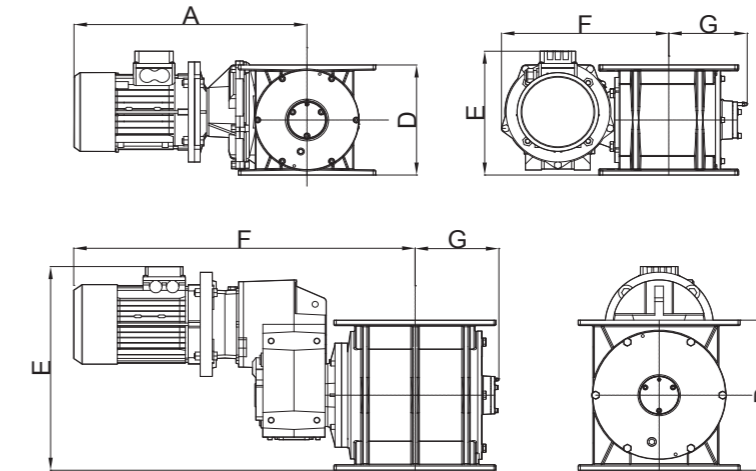
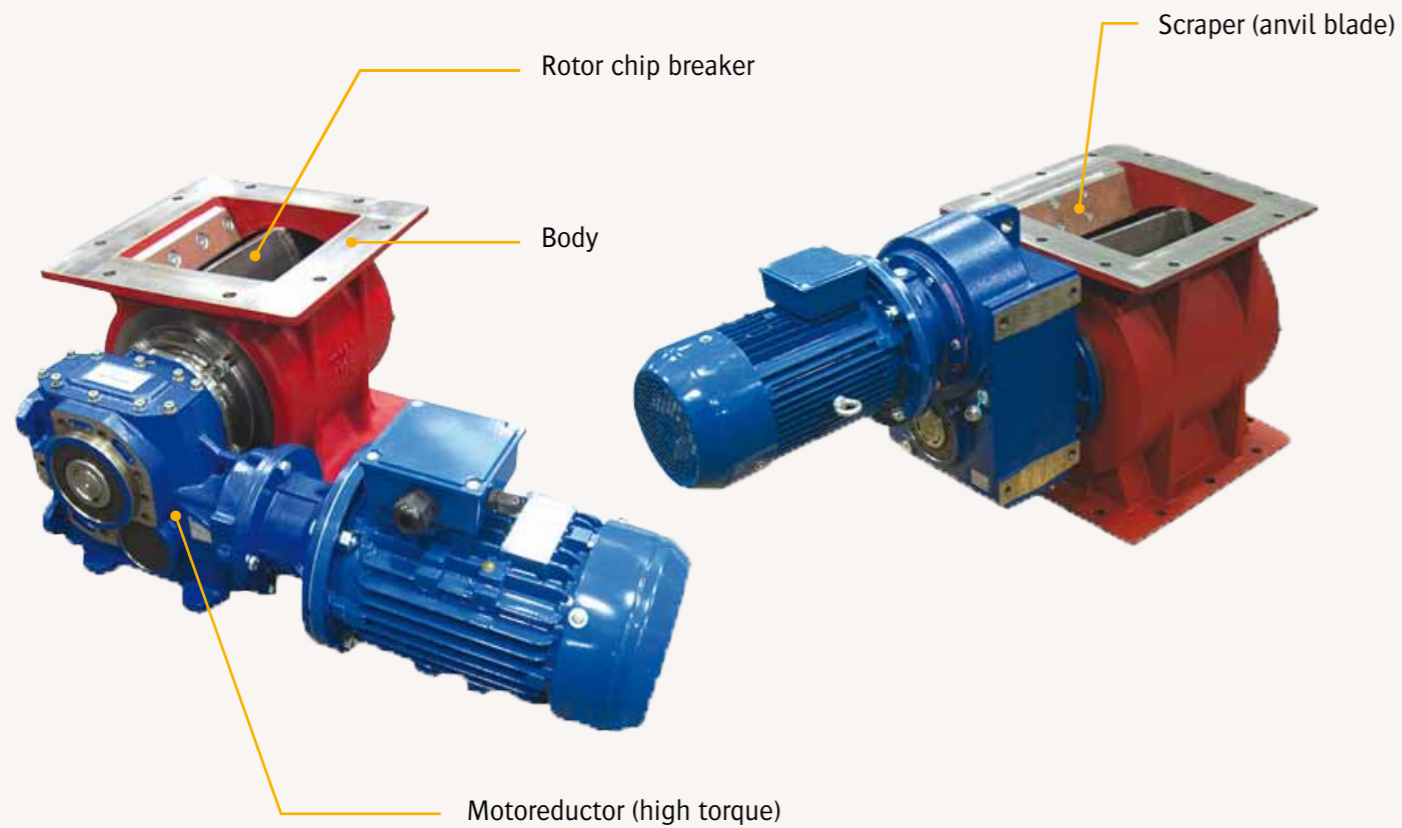

Models	A*	D	E*	F*	G	Motor speed (rpm)	Motor Power (kW)	Dosing flow rate (L./t.)
RWN 02	500	220	248	325	131	20	0.75	2.2
						30	1.1	
RWN 05	540	280	237	340	162	20	1.1	5.4
						30	1.5	
RWN 10	-	360	490	792	188	20	1.5	10.9
						30	2.2	
RWN 20	-	455	561	855	226	20	2.2	19.5
						30	3.0	