

**FINE CHEMICAL
INDUSTRY
DIVISION**

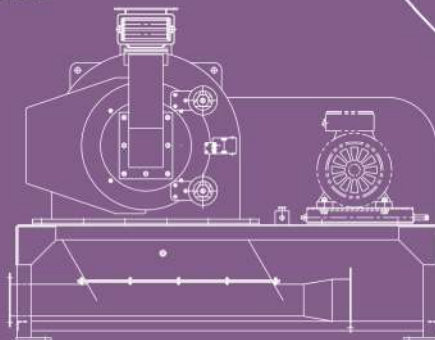

*Bulk material & powder
handling solutions*





Hair cream skid

- 4 - Fine Chemical Industry Division
- 6 - Factory & production line designer
- 8 - Your project
 - Turnkey solutions
 - Engineering / Audit
 - Examples of realisations
- 14 - Automation & electricity
- 16 - Equipment
- 18 - Services
 - Test plant
 - Assembly
 - Commissioning
 - Customer services
- 22 - Atex and sectors

SUMMARY

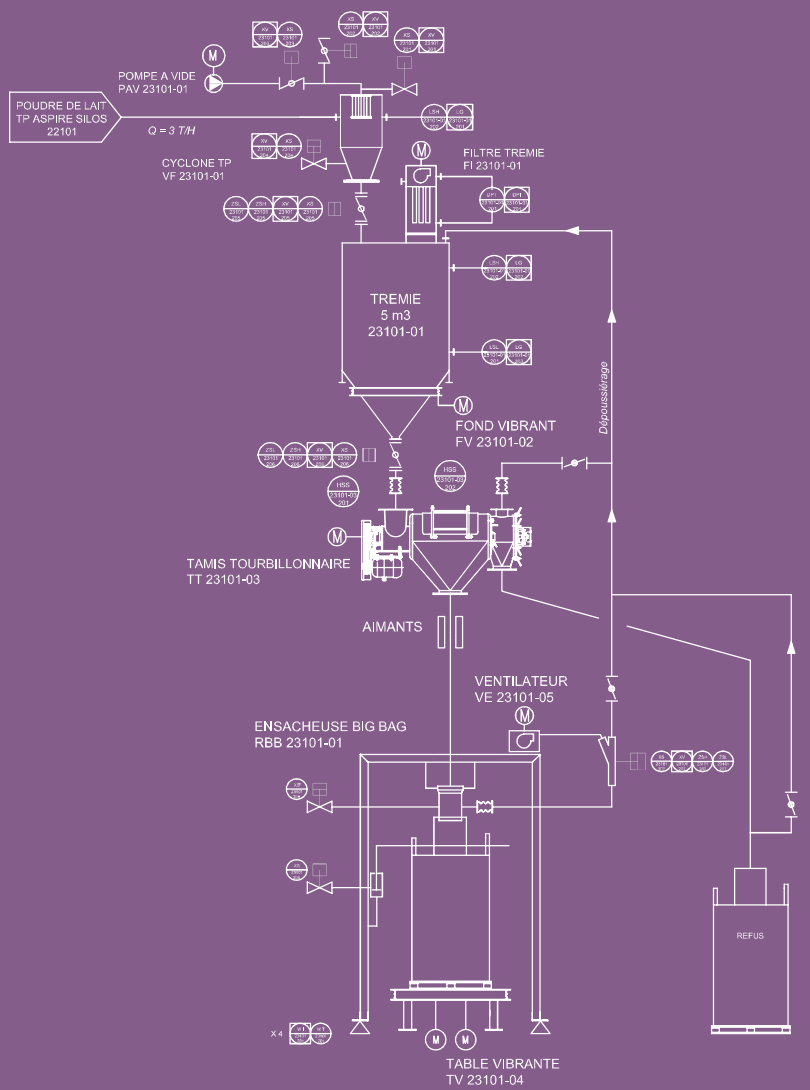

EXPERTISE & TECHNOLOGY

Our clients are often faced with the relative competitiveness and requirements relating to the product quality. PALAMATIC PROCESS integrates into its production line designs equipment to meet the constraints of traceability, precision dosing, mixing quality and high production rates. From the reception of raw material to the packaging of «finished products», we guarantee an optimal process ensuring consistent quality of production and performance under control. Our innovative and high quality equipment is perfectly adapted to the high standards of the fine chemical industry. Our engineers master perfectly the problems of these sectors and define the ideal equipment with you.

PALAMATIC PROCESS ensures the success of your project.



RECOGNISED EXPERTISE

Optimal knowledge of the world of fine chemical industry production provides PALAMATIC PROCESS customers an assurance of quality for the success of their production line, and / or integration of new equipment. The cosmetics, health and pharmaceutical industry sectors require rigid hygiene and security constraints.

Our innovative and quality equipment is perfectly adapted to the high standards of the fine chemical industry and provide a better match with its constraints (process in cleanroom, nitrogen inerting...).

Our offer includes:

- Atex standards
- Accuracy batch
- Accurate dosage
- Quality of mixtures and dissolutions

- Easy cleaning with «Clean In Place» CIP / NEP
- In compliance with rules of cross-contamination
- Containment of toxic products

PALAMATIC PROCESS provides a customised service for the definition of manufacturing process by integrating innovative and reliable technologies. Each device provides a perfect match with the constraints of the chemical industry. Over time, we have developed complete and comprehensive expertise in the field of project management. This expertise is applied to any plant from the simple platform (for the preparation of a product) to the entire factory.

Our many years of experience in various fields of activity allows us to offer you the benefits of inter-sector synergy.



FINE CHEMICAL INDUSTRY DIVISION

- PHARMACEUTICALS
- COSMETIC COMPOUNDS
- BIOTECHNOLOGY
- PRODUCTS ASEPTIC TREATMENT
- DETERGENT AND WASHING PRODUCTS
- AROMAS



FACTORIES & PRODUCTION LINES DESIGNER

Our engineering team and technicians are trained on different technologies and attentive to our customers in order to deliver adequate optimized installations with specifications that are imposed upon us.

Our conception is modelised in 3D with SolidWorks to give our customers the possibility of a better «in space» visualization of the design and integration proposals. Do not hesitate to contact us for your projects, be they new equipment integration in your production lines or full turnkey installations, we are at your disposal to draft a detailed technical proposal.

- PRODUCTION FEEDING
- TRANSFERRING
- SIFTING
- STORING
- DOSING
- MIXING
- PACKAGING
- AUTOMATING
- ASSEMBLY
- TRAINING



■ MEDECINES ■ IBUPROFEN ■ ASCORBICACID ■ SORBOSE ■ SORBITOL
■ GLUCOSE ■ ENZYME ■ CYSTEINE HYDRATE ■ HAWTHORN ■ BORIC
ACID ■ MANNITE ■ SOAP ■ MALTODEXTRINE ■ CHLORIDE OF PAVAVERINIUM

Containers or pneumatic conveyor ?

Based on your production, our engineers select batch and continuous techniques.



Weighing, by-weight proportioning, additives, micro-ingredients or loads?

PALAMATIC PROCESS integrates the optimal solution by implementing volumetric, weight, or integrated dosing in-line on conveyors. Our many years of experience in the agri-food industry, chemical, pharmaceuticals, and animal nutrition allow us to offer you the benefits of this expertise.



2 APPROACHES TO ENSURE THE SUCCESS OF YOUR PROJECT

PROGRESS OF PROJECTS

- ① DESIGN-ENGINEERING
- ② PLANNING
- ③ MANUFACTURING-PRODUCTION
- ④ AUTOMATION & ELECTRICITY
- ⑤ ASSEMBLY
- ⑥ COMMISSIONING





1

TURNKEY SYSTEMS

Your product is unique! PALAMATIC PROCESS integrates innovative optimal solutions with custom equipment defined by our highly skilled experienced engineers. With attentiveness, reflection, and projection, our sales engineers provide you, through on-site visits, personalized studies and recommendations based on your current and forecast production. The wide range of feeding, conveying, mixing, lump breaking and milling equipment mastered by PALAMATIC PROCESS and the possibility of conducting tests in our test plant guarantees the success of your project and your production line's reliability.

Project management

To meet your deadlines, we give importance to the establishment of a detailed schedule on MS Project

for each project. This planning stage guarantees a better visibility of project progress to meet the contractual delivery dates.

Upon receipt of order, PALAMATIC PROCESS edits a program and plans for approval. Scheduling is updated on a regular basis in order to meet contractual delivery dates.

Validation of equipment, as those of our designs or integrated equipment, forms the subject of a special undertaking in order to comply with the specifications.

Any subcontracting is also subject to qualification and strict control. All equipment and systems are subject to provisional acceptance. The technical folder is elaborated throughout the project to make it complete and ready for commissioning.



2

« ENGINEERING / AUDIT »

To better fulfill your needs, PALAMATIC PROCESS **proposes advancing step by step**. This approach corresponds to **delegating a specialist engineer or team of engineers to your site** at any stage in your project: simplified preliminary draft (SPD), detailed preliminary draft (DPD), detailed technical specifications (DTS), tender package (TP), construction monitoring... With this engineering configuration, PALAMATIC PROCESS is positioned as **a catalyser for your project's progress**. Given our strong experience and the specific competence of our design engineers, you are ensured to get the best results regarding flow management, production machine occupancy

rate, equipment layout configurations, building volumes, standards and regulations (ATEX) and precise budgeting of your project.



MS Project planning



*SolidWorks software representation
of Atex cyclofilter*



Final realisation

*Medecines plant,
veterinary products*

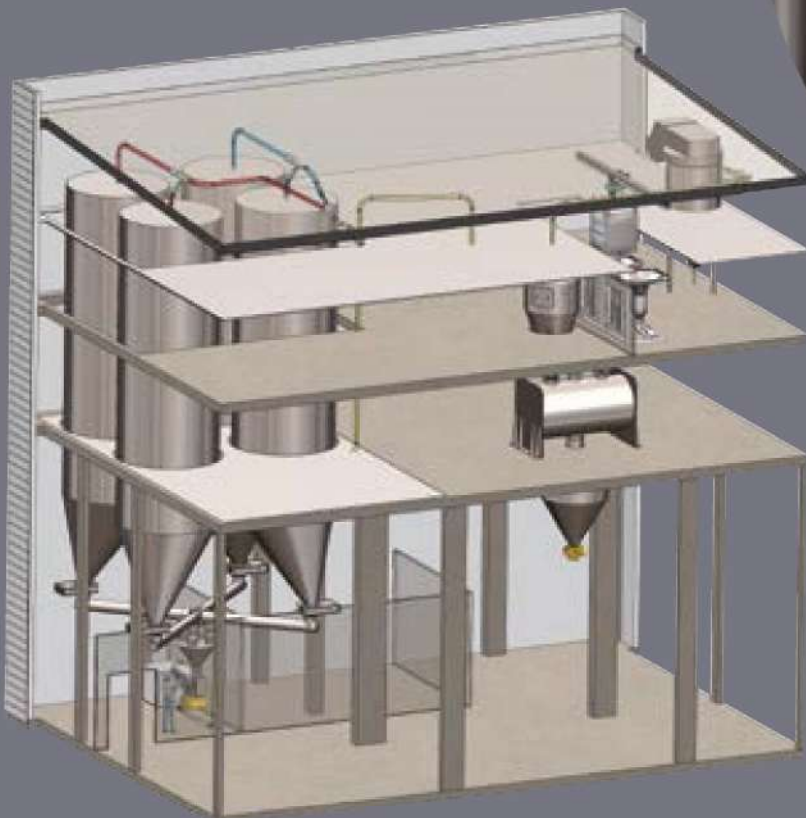
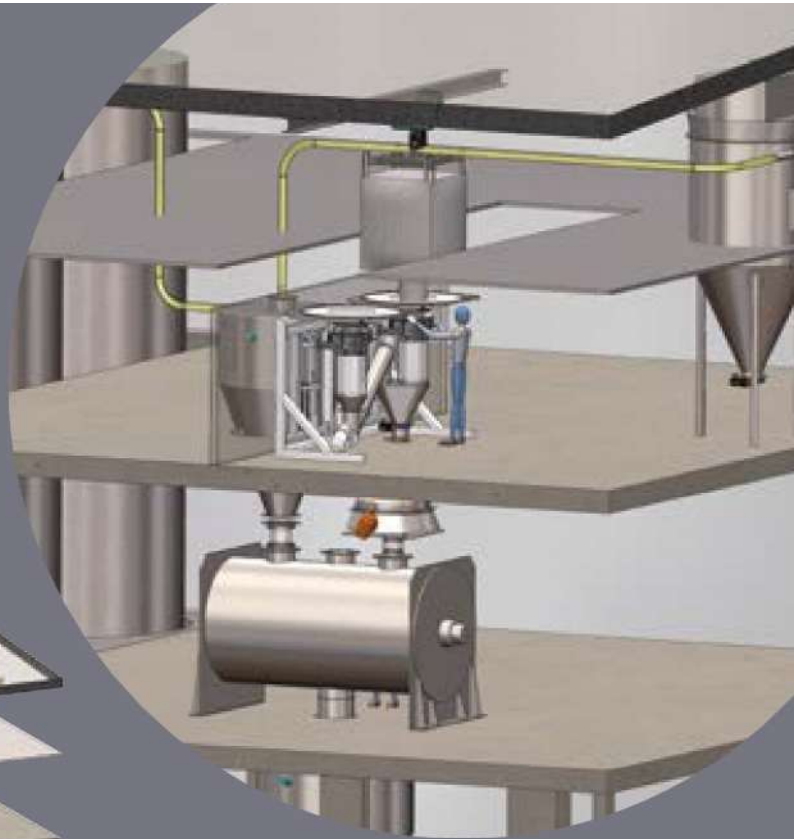

EXAMPLES OF INSTALLATIONS



► GELATIN COATING FOR CAPSULES



CLIENT : pharmaceutical plant (capsule, oral)

OBJECTIVES :

- 1 - To Ensure the feeding of the melter with virgin gelatine (separation of dust and grain)
- 2 - To move from the storage room to the gray area and then to the white zone without contamination
- 3 - To select and dose the gelatin before introducing it through the bottom of the melters
- 4 - To ensure the transfer of the product into the reactor under vacuum and at high temperatures

PALAMATIC PROCESS EQUIPMENT : hygienic fibc discharging system with handling cage, pneumatic conveying integrating the particle size separation, dosing and incorporation hopper with total emptying.

PALAMATIC PROCESS INSTALLATION : PALAMATIC PROCESS has developed a very specific design to ensure maximum hygiene for all areas : pallets loading / handling cage, channeled conveying air of the clean room. The conveying system ensures multiple functions thereby minimizing the number of equipment installed. Functions performed : dosing, particle size separation, transferring, introduction into the melter.

RESULTS OBTAINED : This innovating concept has become a PALAMATIC PROCESS specialty. The design of pneumatic conveying equipment allows minimum equipment for maximum functionality.

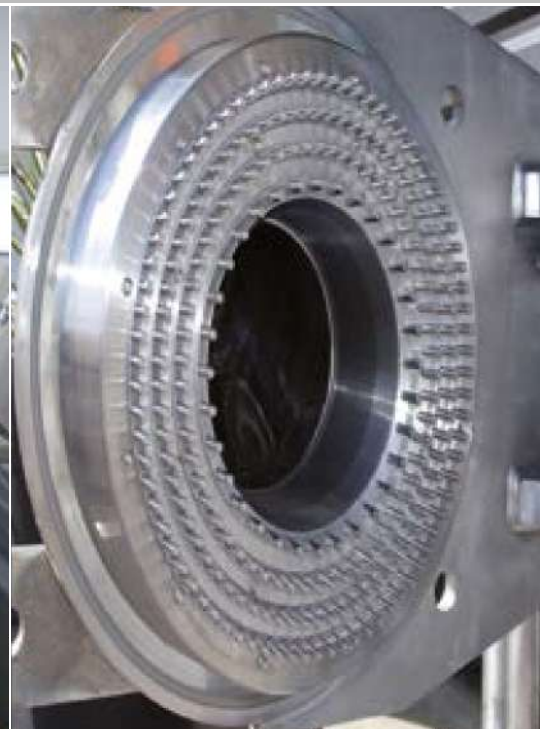

▶ COMPLETE MICRONIZATION AND BAGS PACKAGING LINE Debacterization of seaweed

CLIENT : manufacturer of organic raw material for the cosmetics industry

OBJECTIVES : seaweed micronization

PALAMATIC PROCESS EQUIPMENT : pin mill, batch mixer,
discharging fibc unit, sack packaging

PALAMATIC PROCESS INSTALLATION : PALAMATIC PROCESS has designed and manufactured a complete line of micronization, debacterization and bag packaging. The pre-ground seaweed is introduced into the pin mill in a controlled manner in order to ensure a micronization <to 40µm. The crushed seaweed is then transferred into the mixer with the incorporation of complementary products. The mixer performs the role of homogenizer and sanitizes the mix by controlled atmosphere. The factory end product is weighed and bagged for sale.

RESULTS OBTAINED : the quality of the final product, guaranteed by the production line, perfectly matches the customer's expectations. The overall PALAMATIC PROCESS turnkey installation was a success for this customised installation.





Power cabinet



Monitoring room



Pal'touch®

AUTOMATION & ELECTRICITY

PAL'TOUCH® technology

As a designer of complete production lines, PALAMATIC PROCESS associates ergonomically and visually programmed PLCs with its production units. Production monitoring is as important as the result. This is why PALAMATIC PROCESS's automation and computer engineers include fool-proofing in raw material inputs, lot traceability, operator identification and dosing reliability. The production line steering screens provide ergonomics and comfort with continuous dialogue during the project execution phase between your production team and our design office.

Schneider, Siemens, Rockwell, Omron, Philips, Intouch, Pc Vue, Vijejo Designer...

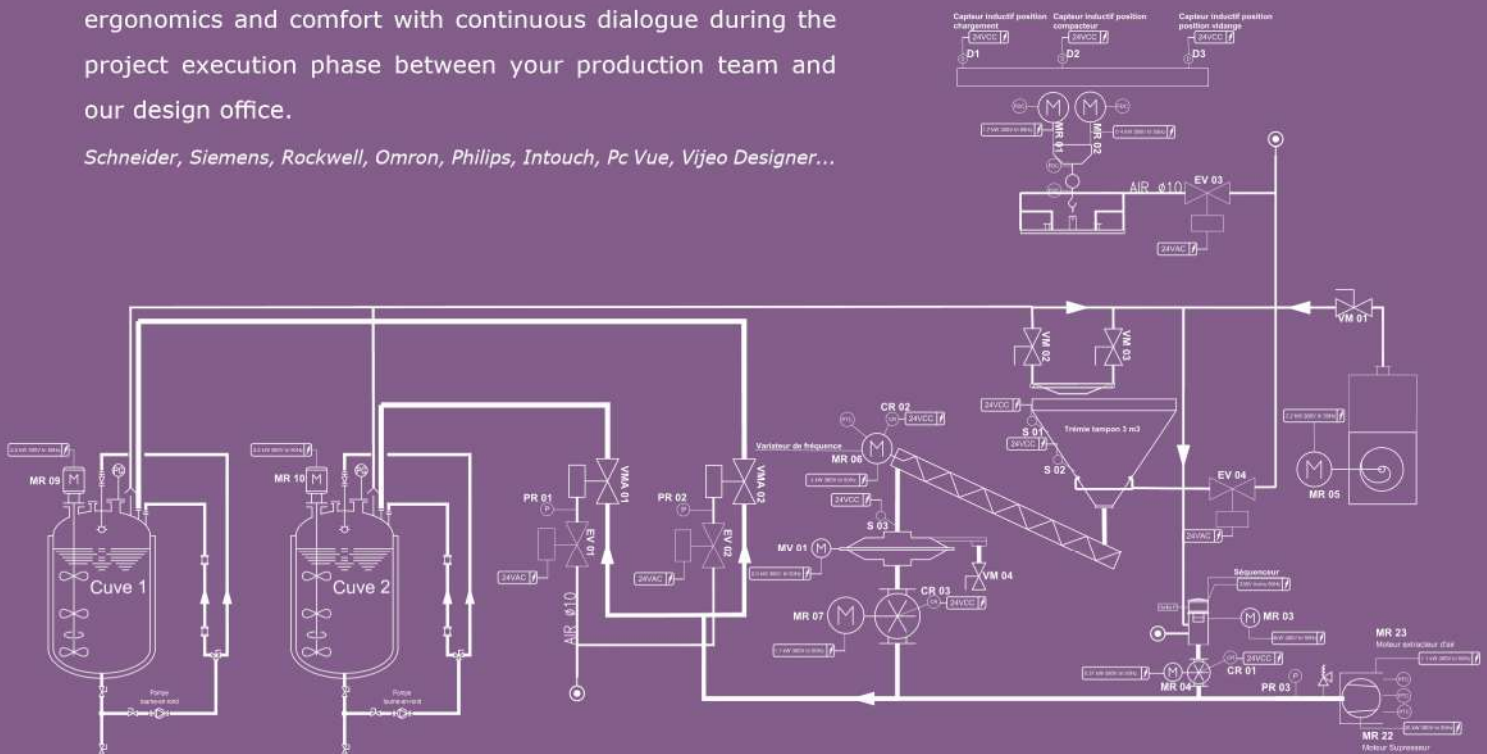

FINE CHEMICAL INDUSTRY DIVISION



Dosing – microdosing – traceability – history – supervision

EQUIPMENT



UNLOADING

Big bag discharging system

To facilitate the flow and containment ensuring ergonomics and operator safety



Bag dump station

Bags opening, handling with manipulator, reduced size device



Automatic sack opening system

Automatic opening with respect for fragile products and high cadence deconditioning



FILLING

Truck loading spout

Efficient loading of powdered and granular materials into tankers or open trucks.



MIXING

Mixer

Mixing 100% solid materials or incorporating liquids up to high viscosity



PNEUMATIC CONVEYING

Cyclone

Vacuum transfer in dense phase for all types of powders without retention and with line purge



Hopper

Vacuum transfer system with integrated weighing system for introduction into melters



Cyclofilter

For receiving powder on pneumatic conveying line



AUTOMATING

Pal'Touch

Lot traceability, operator identification and dosing reliability... Production monitoring is as important as the result



DOSING

Trough and tubular screw conveyor

Mechanical conveying for pulverulent



Product feeding with pneumatic conveying

Weight or volume feeding for powders and granulates



Rotary valves

Gravity or blow through rotary valves for the dosing of powders and the feeding of pneumatic conveying



GRINDING

Blade grinder

Micronization of your powders, blades technology, pins and hammers



Granulator

Crushing of materials that tend to form clumps and ensure the fluidity of the product



Centrifugal sifter

Implementation of the sieve on a pneumatic conveying line



Vibratory sifter

Sieving for the protection of the line, elimination of agglomerates and foreign bodies



PRODUCTION FEEDING

Big bag filling station

Manual or automatic bagging unit for bulk and granular powders



Big bag packaging

Conditioning of all types of big bags in a contained manner with densification and commercial weighing



STORING

Silos / Hoppers

For storage of your powders and granules, steel, stainless steel or aluminum manufacturing and flexible silos



Stainless steel / steel container

For storage of your powders and granules, standard or customised models from 500 to 2500 l.



▶ TEST PLANT

Always with the aim to satisfy and provide you, the client with the best solutions for powders, PALAMATIC PROCESS can perform tests thanks to its in house **test centre** and its **demonstration equipment**.

- Pneumatic dense phase suction conveying
- Dosing
- Big bag unloading
- Milling
- Sifting

Thus, we validate the parameters required for your own products. This allows you to judge the performance of the PALAMATIC PROCESS equipment and secure your investment.

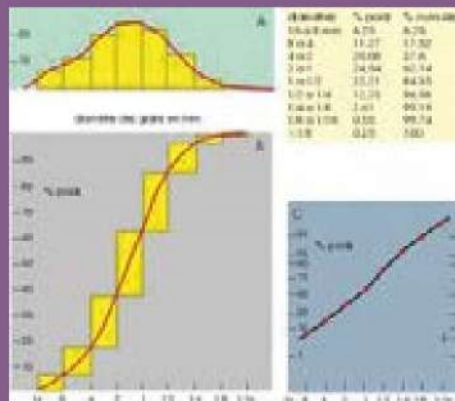

Granulometric curve





Palamatic Process workshop

▶ ASSEMBLY

We perform or supervise every step of your project from assembly to final commissioning. We can offer you a complete quality service with respect for your deadlines. The installation of our equipment in your premises is performed by our technicians anywhere in the world. The assembly of your production line includes handling, mechanical assembly, supporting piping and electrical wiring.

▶ COMMISSIONING

The commissioning stage provided by PALAMATIC PROCESS ensures the respect of your specifications. It includes:

- Final adjustments of the whole system by qualified personnel
- Checking of electrical connections
- Conducting of production tests

Training :

PALAMATIC PROCESS provides comprehensive training to ensure optimal use of your production line. All your production, line conducting and maintenance teams are trained throughout the start phase.

A comprehensive and customised technical start up documentation is supplied with every installation.



Plant installation





<https://www.palamaticprocess.com/bulk-handling-equipment/mixer>

► SERVICE

Customer services and maintenance on site

We guarantee after-sales service and quick delivery of spare parts and worn parts. Our service also proposes maintenance contracts adapted to your need.

PALAMATIC PROCESS after-sales service technicians move on site to provide the best solutions to your problems. Regular visits from one of our technicians guarantees operating efficiency and extends the life span of your installation.

Each of our technicians has received comprehensive technical training. Remote diagnostics are integrated into the automatons for increased reactivity. PALAMATIC PROCESS uses teleservice systems allowing remote diagnosis and support in a short time even if the clients are located far away.



FINE CHEMICAL INDUSTRY DIVISION



Dietary supplements skid

ATEX REGULATIONS

AUDIT AND COMPLIANCE



In your production processes, you are very frequently faced with the explosive nature of several materials like powder, gas or liquid. Explosions have huge consequences. When the atmosphere is explosive, a small spark (e.g. that of an electric switch or from the mechanical heating of a part of the machine) is enough to cause an accident or a disaster.

For many years, authorities and industries have worked on developing safety rules governing work conditions in such dangerous environments : explosive atmospheres. The new regulations, called ATEX regulations, were published and are effective as of the 1st of July, 2003.

PALAMATIC PROCESS provides its expertise to classify your risk zones based on the nature, frequency or duration of the presence of an ATEX regulation.

Today, PALAMATIC PROCESS delivers to its customers ATEX installations certified by notified organisms (Inéris, LCIE ...). PALAMATIC PROCESS has developed as a standard some equipment conforming to ATEX 0-20 / 1-21 / 2-22. Our engineers perform the zoning and drafting of risk analysis on new equipment and new facilities. PALAMATIC PROCESS ensures safe operation and full compliance with these standards.



80% of the installations delivered by Palamatic are ATEX compliant

5 SECTORS

PALAMATIC PROCESS created five specific divisions to offer customers an efficient project team sensitised to constraints of these sectors.

FOOD & FEED

BABY FOOD ■ SPICES AND FLAVOURINGS
■ MILK DAIRIES ■ ANIMAL NUTRITION FOR LIVESTOCK ■ PETFOOD ■ MILLS ■ BAKERIES
■ SUGAR INDUSTRY ■ CONFECTIONERY ■ BEVERAGE AND JUICE MANUFACTURING ■ DIETARY SUPPLEMENTS ■ PRE-PREPARED MEALS



CHEMICAL INDUSTRY

PETROCHEMICALS ■ PLASTICS ■ PAINT
■ PIGMENTS AND DYES ■ PESTICIDES AND FERTILIZERS
■ PAPER PRODUCTION
■ TEXTILE MANUFACTURING



FINE CHEMICAL INDUSTRY

PHARMACEUTICALS ■ COSMETIC COMPOUNDS ■ BIOTECHNOLOGY
■ PRODUCTS A SEPTIC TREATMENT ■ DETERGENTS AND WASHING PRODUCTS
■ AROMAS



MINERALS & BUILDING INDUSTRY

CEMENT PLANTS ■ QUARRIES ■ INDUSTRIAL PLASTER (BOARDS AND POWDERS) ■ GLASS MANUFACTURING
■ MINERALS AND METALS



WASTE WATER & SMOKE TREATMENT

PREPARATION OF WHITWASH ■ DISSOLUTION OF UREA ■ TREATMENT OF ACTIVATED CARBON ■ ALUMINUM SULFATE TREATMENT ■ SLUDGE PROCESSING / TRANSFER / STORAGE / COOLING





www.palamaticprocess.com



*Bulk material &
powder handling solutions*

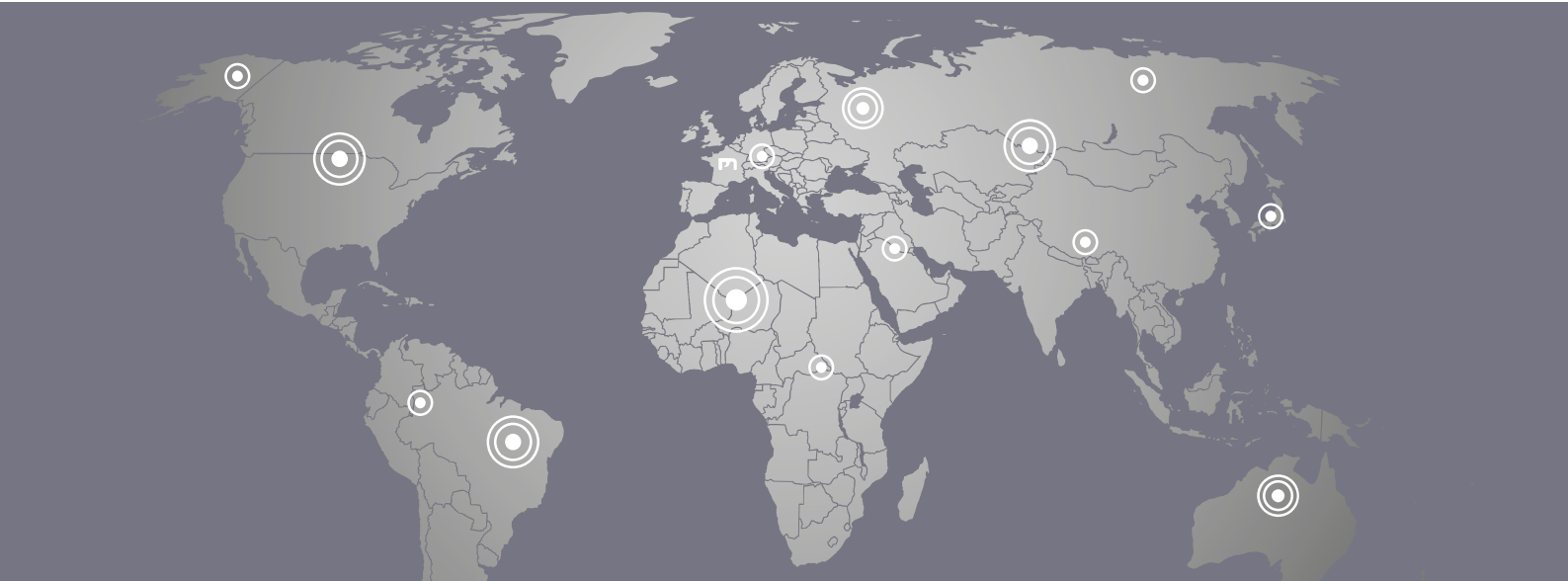

contact@palamatic.fr
ZA La Croix Rouge • 35530 Brécé • France
Tél. : +33 (0) 2 99 86 06 22
Fax : +33 (0) 2 99 86 08 10