

# Vertical Mixer



## Monorotor

Capacity: 500 to 4,000 litres

**HIGH MIXING QUALITY DUE TO THE THREE-DIMENSIONAL EFFECT**

The vertical mixer with single shaft performs quality mixing of dry, moist and viscous materials. This mixer is ideal for the food industry as it complies with hygienic standards. It provides excellent mixing results, regardless of the materials to be mixed, through the helical movement of the central blade.

### ▶ DIMENSIONS in mm

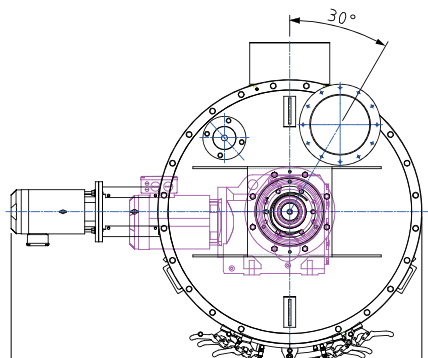
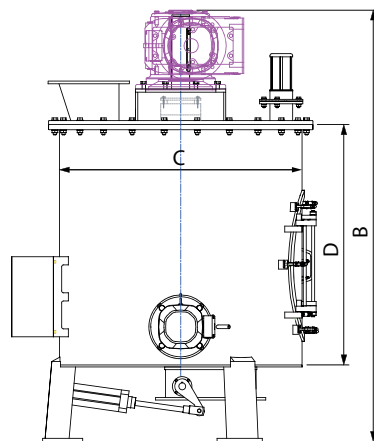
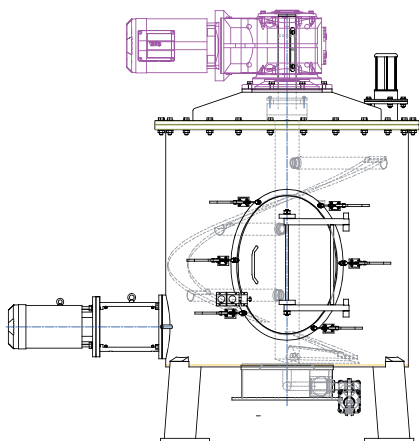

Models	Mixing capacity (L)	A	B	C	D	Power kW
VM 500	500	2,050	1,900	880	1,115	7,5
VM 1000	1,000	2,050	2,155	1,212	1,200	11
VM 1500	1,500	2,250	2,600	1,410	1,235	11
VM 2000	2,000	2,350	2,600	1,515	1,500	15
VM 3000	3,000	2,350	3,550	1,515	2,200	22
VM 4000	4,000	2,750	3,400	1,900	1,900	30

## Case Studies



### ▶ MIXING LINE AND BABY FOOD HOMOGENIZATION

**Client:** Food factory

**Materials:** Milk powder and vitamins

**Installation details:** Loading of the ingredients packed in big bags and sacks with pre-weighing in a dedicated room to ensure complete hygiene.



### ▶ PRODUCING A PREMIX FOR SPREAD MANUFACTURING

**Client :** Dairy products

**Materials:** Milk powder, sugar, alginate cocoa

**Installation details:** Preparation and mixing line with manufacturing in masked time for introduction into a powder disperser. This technology was chosen for its cleanliness and sanitation characteristics considering the absence of bearing in the product. The prepared mixture is packed in containers thus allowing management of masked time.

