

SOLUTIONS

Sacks & Drums

EMPTYING

COMPACTING

HANDLING

DISCHARGING



Palamatic
PROCESS >>> machines • engineering

Bulk Material & Powder Handling Solutions

CONTENT



Means that the equipment is available for testing at PALAMATIC PROCESS



Means that the equipment can be installed in ATEX zone



Means that design and options can be customised

PALAMATIC PROCESS reserves the right to make changes in the design of the facilities listed in this commercial documentation

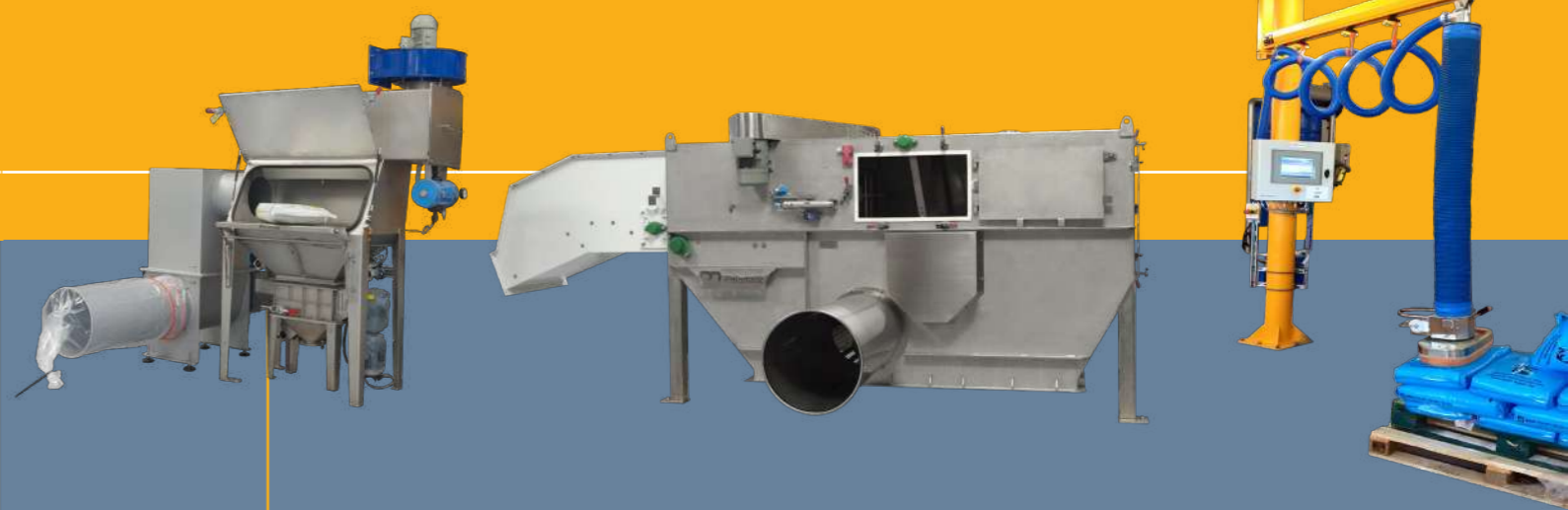

RANGE OF MANUAL SACK OPENING SYSTEMS 04

- Sacktip®: STANDARD model 04
- Sacktip® Enclosed: DUST CONTAINMENT model 08
- Sacktip® Hygienic: with INTEGRATED SIEVE 12
- CUSTOM MADE manual bag dump station 16

OPTIONS FOR MANUAL BAG DUMP STATIONS 18

CONTAINMENT AND ERGONOMICS 20

- Sack compactor 20
- Vacuum sack lifter 22
- Suction booth 24
- Pouyès ring 26

RANGE OF AUTOMATIC BAG DUMP STATIONS 28

- Ergotip® 28
- SAS® 30
- Minislit® 34
- Rotaslit® 38
- Varislit® 42
- Autotip 46

DRUM DISCHARGING SYSTEMS DRUMFLOW® 50

- DrumFlow® 01: suction tube 51
- DrumFlow® 02: discharge by extraction of the sack 51
- DrumFlow® 03: tilting 52
- DrumFlow® 04: tilting and capping 53

<p>Sacktip®</p>  <p>2 - 6 sacks/min. Ergonomics</p> <p>▼ Page 04</p>	<p>Sacktip® Enclosed</p>  <p>2 - 6 sacks/min. Ergonomics & containment for toxic products</p> <p>▼ Page 08</p>	<p>Sacktip® Hygienic</p>  <p>2 - 4 sacks/min. Protection against foreign bodies</p> <p>▼ Page 12</p>	<p>Custom made manual unit</p>  <p>2 - 6 sacks/min. Ergonomics, adaptability to constraints</p> <p>▼ Page 16</p>	<p>Ergotip®</p>  <p>6 sacks/min. Ergonomics and safety for the operator</p> <p>▼ Page 28</p>	<p>SAS®</p>  <p>2 - 4 sacks/min. Difficut products and ATEX zones</p> <p>▼ Page 30</p>	<p>Minislit®</p>  <p>8 sacks/min. High rate for all types of sacks</p> <p>▼ Page 34</p>	<p>Rotaslit®</p>  <p>6 sacks/min. Robust manufacturing for all types of sacks</p> <p>▼ Page 38</p>	<p>Varislit®</p>  <p>12 sacks/min. High rate</p> <p>▼ Page 42</p>	<p>Autotip®</p>  <p>15 sacks/min. Very high rate and automation</p> <p>▼ Page 46</p>
--	--	--	---	--	--	---	--	---	--

Basic configurations and applicable options

CAPTION: X Included Options Not available

	Sacktip®	Sacktip® Enclosed	Sacktip® Hygienic	Custom made manual unit	Ergotip®	SAS®	Minislit®	Rotaslit®	Varislit®	Autotip®
Sack opening rate (the highest rate may vary according to the operator and the type of sack)	2 - 6 sacks/min.	2 - 6 sacks/min.	2 - 4 sacks/min.	2 - 6 sacks/min.	6 sacks/min.	2 - 4 sacks/min.	8 sacks/min.	6 sacks/min.	12 sacks/min.	15 sacks/min.
Mobile station on wheels										
Dust-proof door		X			X	X				
Security screen	X	X	X		X	X	X	X	X	X
Sliding bars		X			X	X				
Foldaway tray	X		X		X	X				
Gravity roller table		X					X	X	X	X
Motorized infeed belt conveyor							X	X	X	X
Integrated sack compactor						X	X	X	X	X
Integrated dust collector										
Integrated lump breaker										
Clean In Place (C.I.P.)										
Dosing and weighing										
Hygienic application			X							

Utilities

Input TOR	0	0	0	According to design	3	5	11	10	9	37
Output TOR	1	1	1	According to design	3	11	3	4	2	13
Installed power (KW)	0,1	0,1	0,6	According to design	0,1	2,5	4,4	5,2	4,5	19,7
Power supply voltage	230V./400V. TRI	230V./400V. TRI	230V./400V. TRI	230V./400V. TRI	230V./400V. TRI	230V./400V. TRI	230V./400V. TRI	230V./400V. TRI	230V./400V. TRI	230V./400V. TRI
Service pressure (bar)	6	6	6	6	6	6	6	6	-	-
Average power consumption (KWh)	0,1	0,1	0,3	According to design	0,1	1,0	4,0	3,5	3,2	9,9
Compressed air consumption (Nm³/h.)	4,3	4,3	-	According to design	5,0	6,3	2,0	2,0	-	-
Dust collecting rate (m³/h.)	-	Depending on the model chosen	-	According to design	-	-	800	800	1,500	2,000

Sacktip®: Manual Bag Dump Station

Standard



4 Standard Models:
S 800 - S 1000 - S 1200 - S 1400

Rate: 2 - 6 sacks/min.
Objective: Ergonomics and Dust Containment

CONTAINED AND ERGONOMIC BAG UNLOADING

The Palamatic Process bag dump stations are designed to improve safe and effective ergonomic functionality for operator bag emptying tasks. The station also provides effective dust collection during the manual process of opening and unloading the bags of powder. All sack stations can be provided with dust collection tappings or integrated dust filters and compactors for disposal of the empty packaging.

MANUFACTURING

Structure and parts in contact with the product: mild steel, 304L stainless steel, 316L stainless steel
Access door: mild steel, 304L stainless steel, 316L stainless steel, plexiglass, antistatic lexan, tempered laminated glass
Sealing: EPDM, NBR, natural rubber, silicone
Finishes: epoxy coated, bead-blast, electro-polishing

OPERATING SEQUENCE

1. Open the door and set up of the removable table
2. Position the bag on the shelf and on the sieve
3. Open the bag
4. Empty the bag
5. Disposal of empty sack into the discharge chute or bag compactor (containment of the waste in a polyethylene sheath)

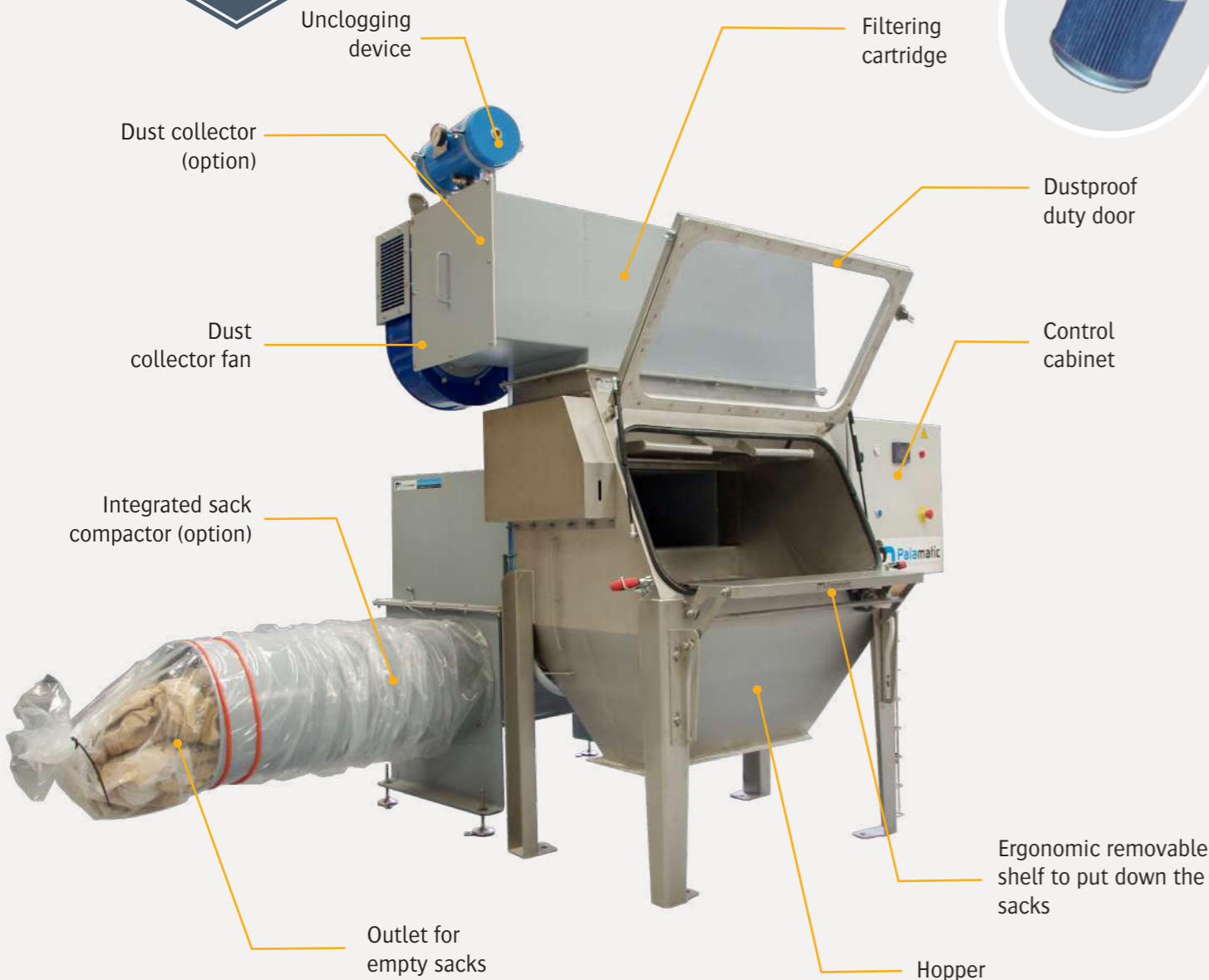

▶ **The gas cylinders** allow the heavy-duty door to be lifted with ease and firmly maintained in an open position



▶ **Ergonomic table for sack loading:** the removable tray allows for a resting area for the bags that need to be opened. Ergonomic height between 32" - 42" for supporting heavy loads. Also includes dust-proof access door that engages the CIP or reverse pulse jet cleaning systems.



▶ **Internal safety grid** facilitates the positioning of the sack and protects the downstream process from foreign bodies.



▶ **Product outlet chute adapted to each particular case:** the slope of the hopper allows clearance for knees and feet

Advantages



STANDARD MODELS

Models	Length of the sacks (mm.)	Flow required for dedusting nozzle (m³/hr.)	Volume* of the hopper (L) *(volume of water)	Unloading diameter (DN)	Height from ground from drain flange (mm.)
S800	650	777	180	250	285
S1000	850	970	225	250	285
S1200	1,050	1,160	265	250	285
S1400	1,250	1,360	300	250	285

*The volume of the hopper is defined according to the process requirements

OPERATING SEQUENCE

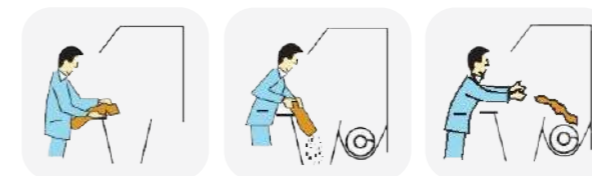

Options



Vacuum sacks lifter



Nozzles/washing rotary heads (CIP)

See all our options on pages 18-19

4 Standard Models:
S 800 - S 1000 - S 1200 - S 1400

MANUAL BAG DUMP STATION

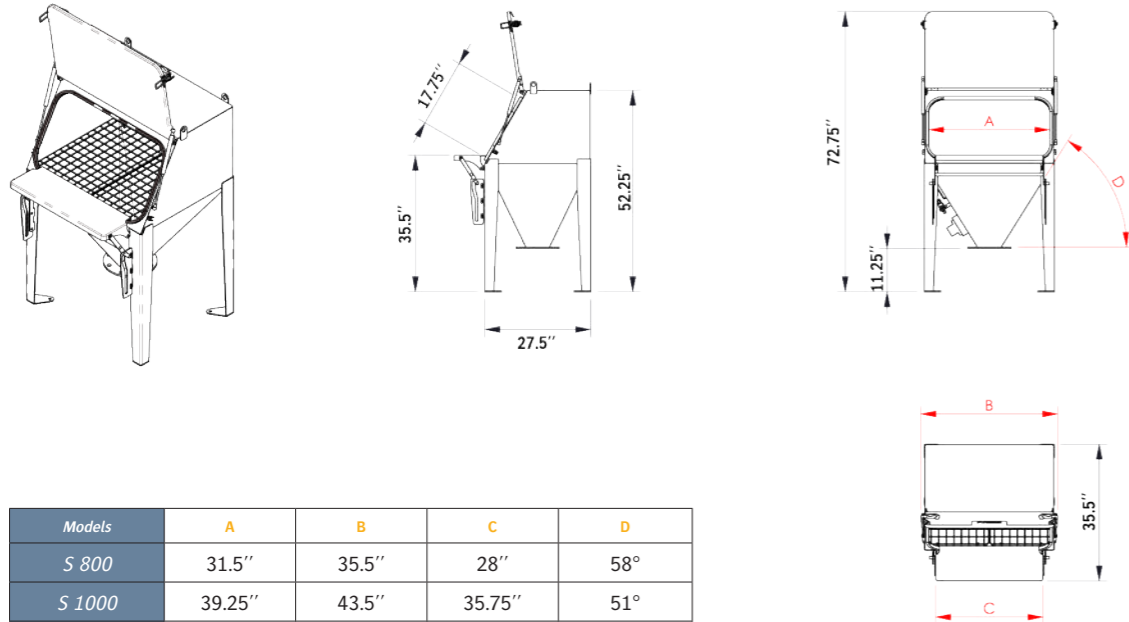

Models	A	B	C	D
S 800	31.5"	35.5"	28"	58°
S 1000	39.25"	43.5"	35.75"	51°
S 1200	47.25"	51.25"	43.75"	45°
S 1400	55"	59.25"	51.5"	41°

OPTION: DUST COLLECTOR

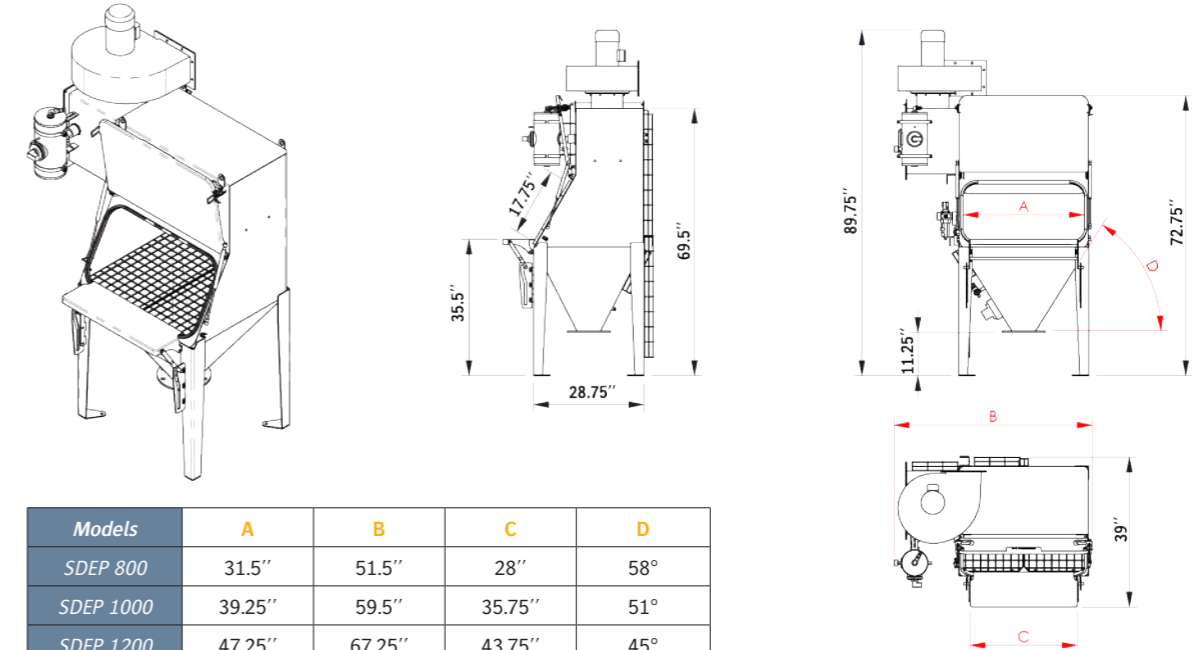

Models	A	B	C	D
SDEP 800	31.5"	51.5"	28"	58°
SDEP 1000	39.25"	59.5"	35.75"	51°
SDEP 1200	47.25"	67.25"	43.75"	45°
SDEP 1400	55"	75.25"	51.5"	41°

OPTION: COMPACTOR

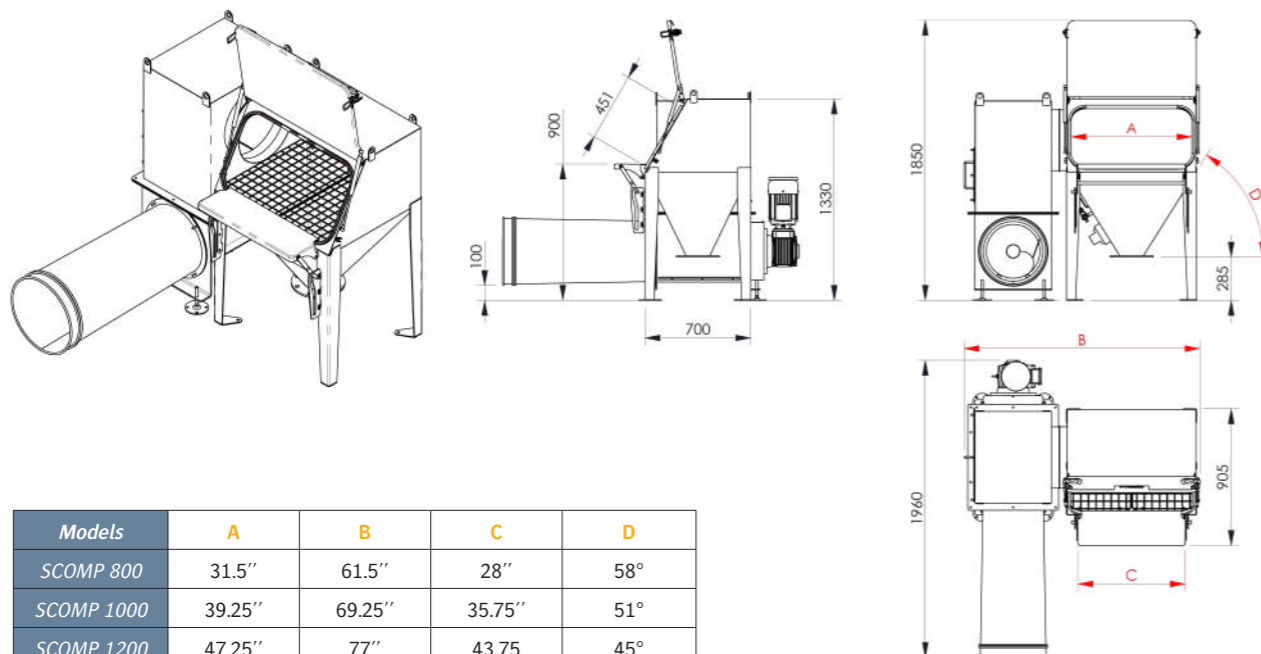

Models	A	B	C	D
SCOMP 800	31.5"	61.5"	28"	58°
SCOMP 1000	39.25"	69.25"	35.75"	51°
SCOMP 1200	47.25"	77"	43.75"	45°
SCOMP 1400	55"	85"	51.5"	41°

OPTIONS: COMPACTOR AND DUST COLLECTOR

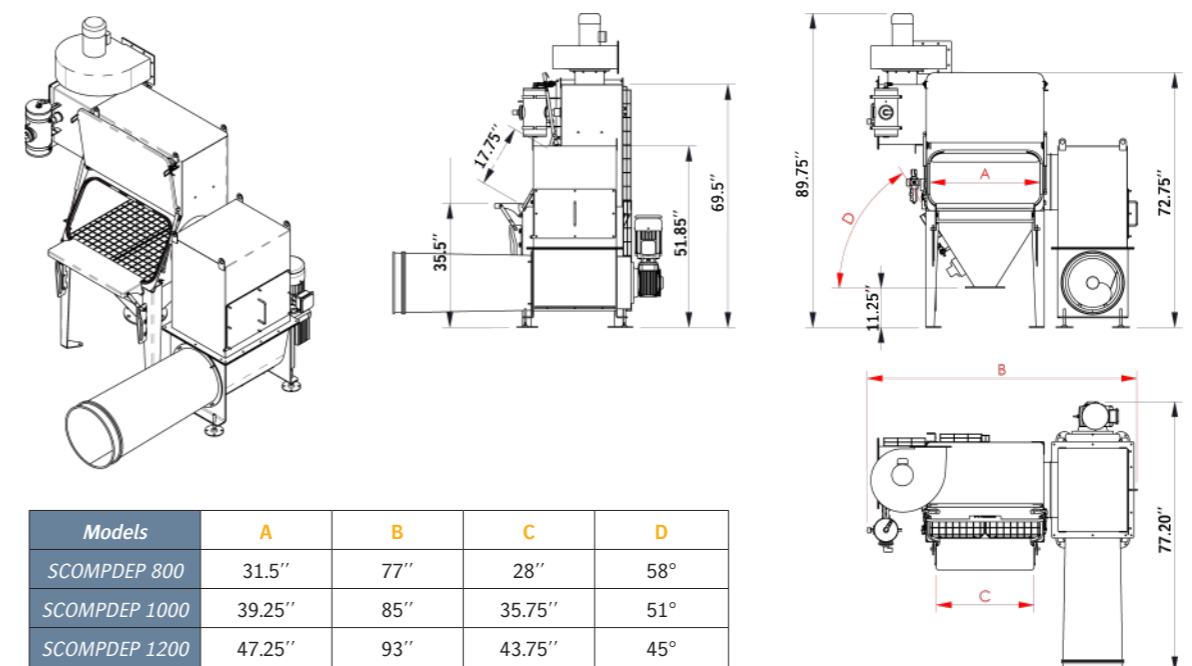

Models	A	B	C	D
SCOMPDEP 800	31.5"	77"	28"	58°
SCOMPDEP 1000	39.25"	85"	35.75"	51°
SCOMPDEP 1200	47.25"	93"	43.75"	45°
SCOMPDEP 1400	55"	100.75"	51.5"	41°

Sacktip® Enclosed: Manual Bag Dump Station

Dust Containment



Sacktip®

4 Standard Models:
SE 800 - SE 1000 - SE 1200 - SE 1400

Rate: 2 - 6 sacks/min.
Objectives: ergonomics and containment for toxic materials

OBJECTIVES

- . Emptying of toxic or hazardous materials
- . Perfect ergonomics
- . Healthy work environment
- . Advanced dust containment
- . Operators protection from harmful dust

MANUFACTURING

Structure and parts in contact with the material: mild steel, 304L stainless steel, 316L stainless steel
Access door: plexiglass, antistatic lexan, tempered laminated glass
Sealing: EPDM, NBR, natural rubber, silicone
Finishes: customized RAL, peening, electropolishing

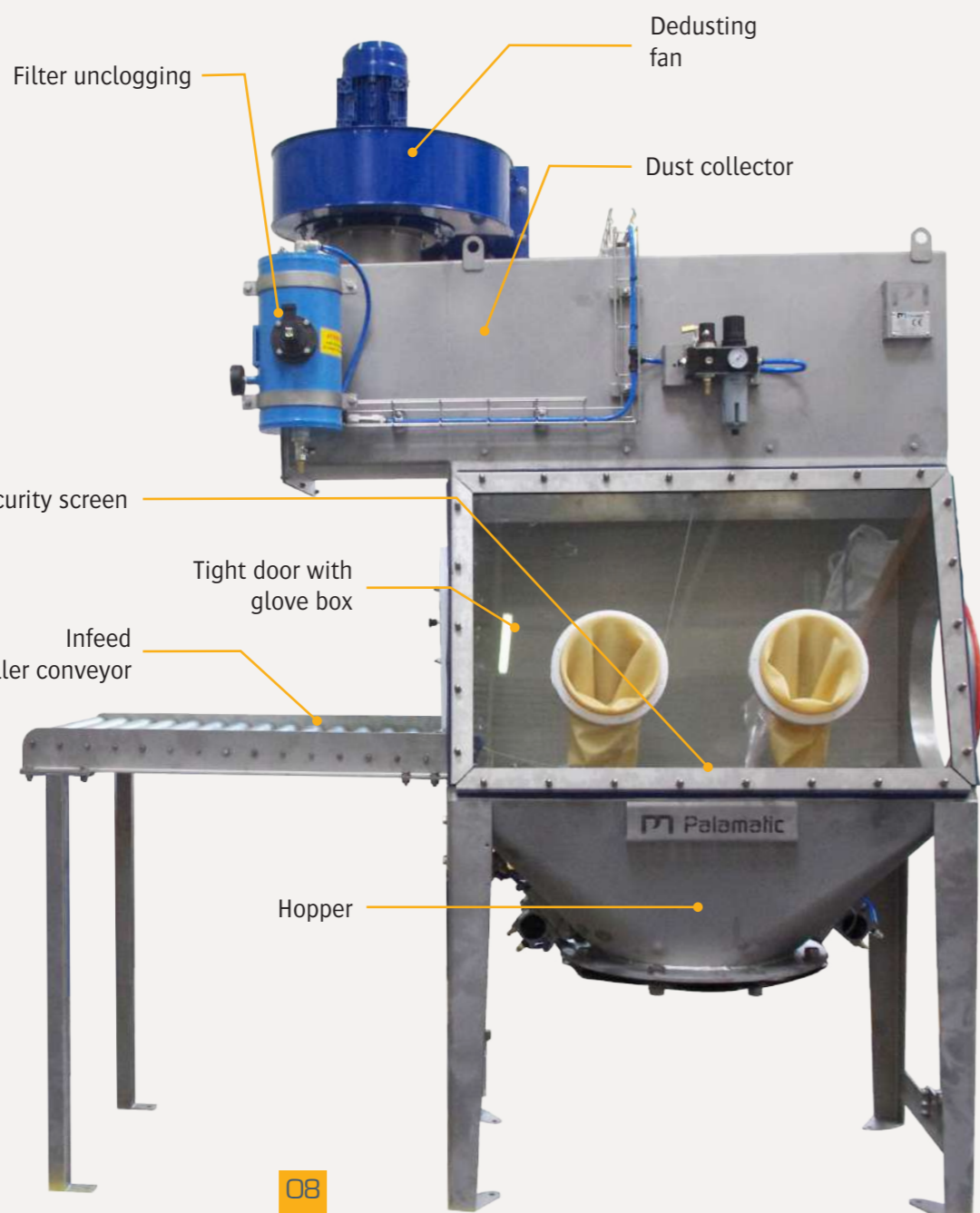

▶ **Glove box** for handling material in a closed and contained area: glass and gloves



▶ **Support** for secured opening tool with support cable



▶ **Mirror-polished finishes** to improve material flow and hygiene. Particularly suitable for the pharmaceutical industry

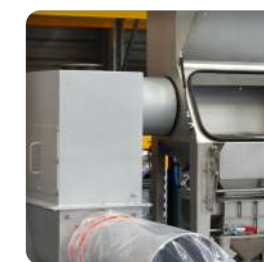

▶ **Side discharge chute for the bag** to maintain a clean working area and to eject the "dirty" emptied sack in a contained area

Advantages



STANDARD MODELS

Models	Length of the sacks (mm.)	Flow required for dedusting nozzle (m ³ /hr.)	Volume* of the hopper (L) *(volume of water)	Unloading diameter (DN)	Height from ground from drain flange (mm.)
SE 800	650	400	180	250	285
SE 1000	850	500	265	250	285
SE 1200	1,050	600	265	250	285
SE 1400	1,250	700	300	250	285

*The volume of the hopper is defined according to the process requirements

ALTERNATIVES

The introduction of sacks can be conducted by a system of sealed lock chamber (alternatives: belt conveyor, roller conveyor ...)



Options



Lump breaker



Drum unloading

See all our options on pages 18-19

Sacktip® Enclosed: Manual Bag Dump Station Dust Containment



4 Standard Models:
SE 800 - SE 1000 - SE 1200 - SE 1400

▶ CONFINED MANUAL BAG DUMP STATION

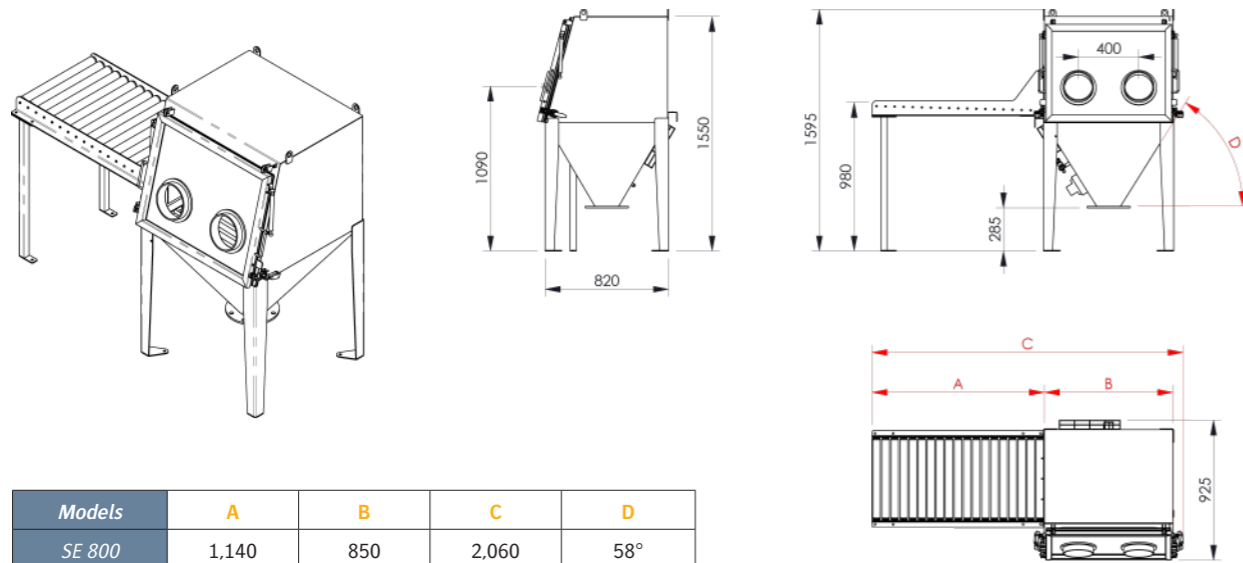

Models	A	B	C	D
SE 800	1,140	850	2,060	58°
SE 1000	1,340	1,050	2,460	51°
SE 1200	1,540	1,250	2,860	45°
SE 1400	1,740	1,450	3,260	41°

▶ OPTION: DUST COLLECTOR

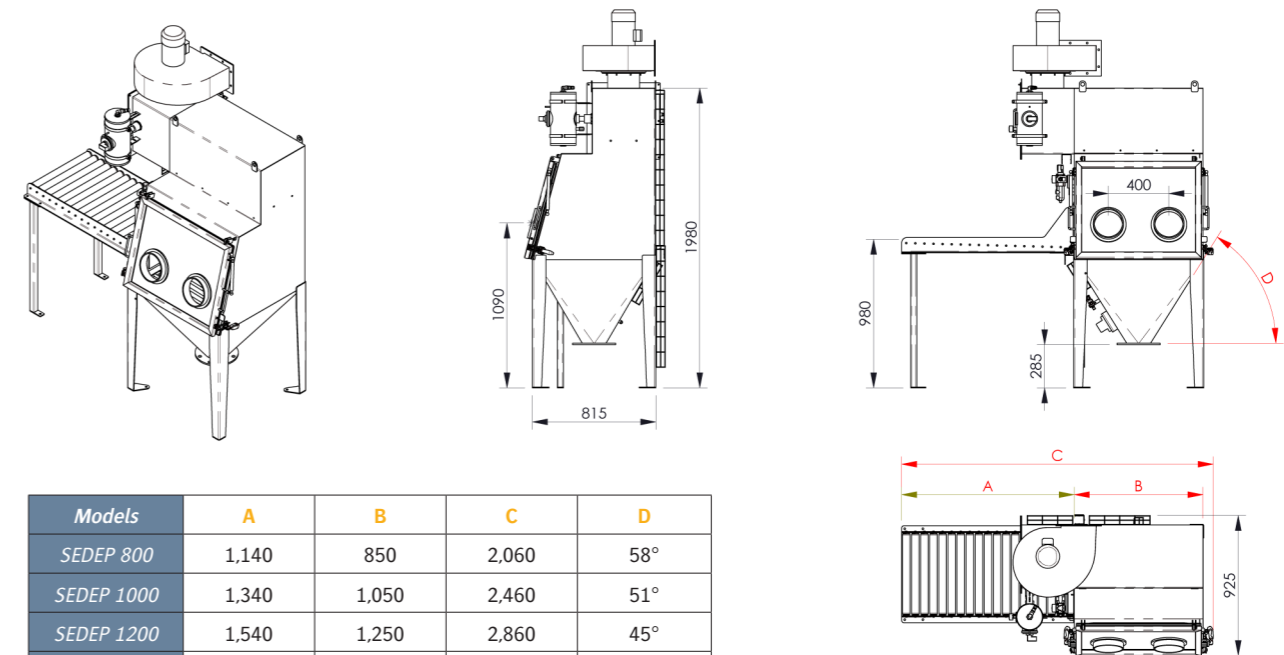

Models	A	B	C	D
SEDEP 800	1,140	850	2,060	58°
SEDEP 1000	1,340	1,050	2,460	51°
SEDEP 1200	1,540	1,250	2,860	45°
SEDEP 1400	1,740	1,450	3,260	41°

▶ OPTION: COMPACTOR

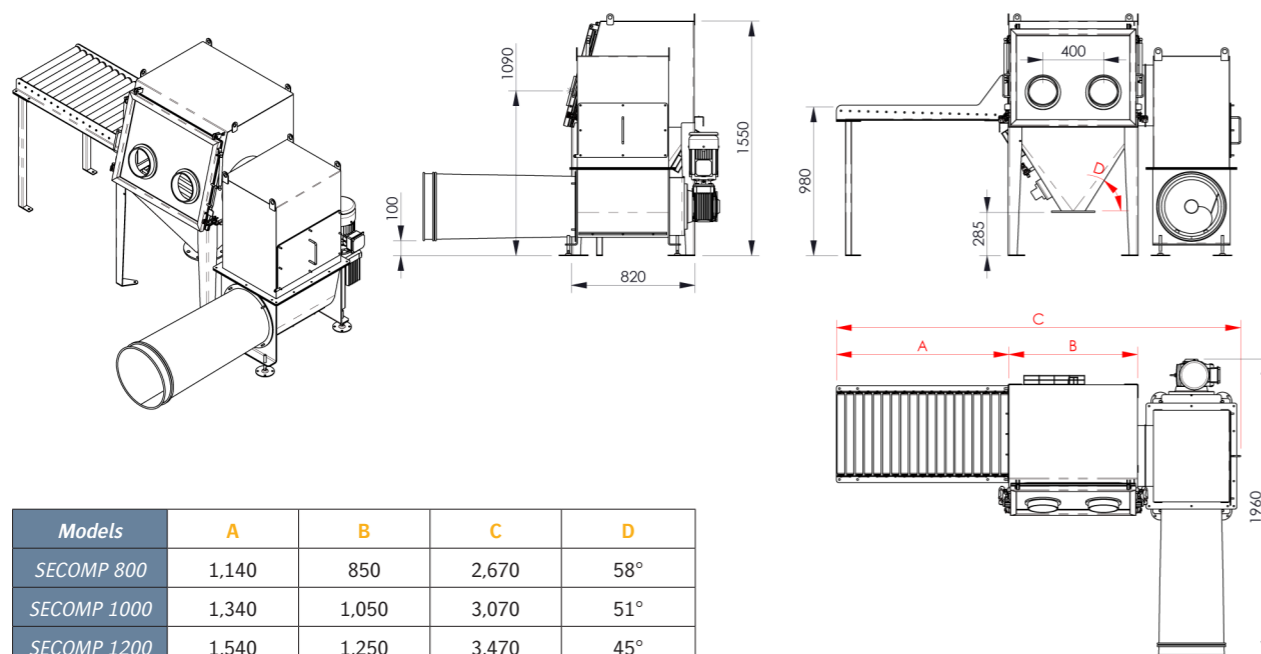

Models	A	B	C	D
SECOMP 800	1,140	850	2,670	58°
SECOMP 1000	1,340	1,050	3,070	51°
SECOMP 1200	1,540	1,250	3,470	45°
SECOMP 1400	1,740	1,450	3,870	41°

▶ OPTIONS: COMPACTOR AND DUST COLLECTOR

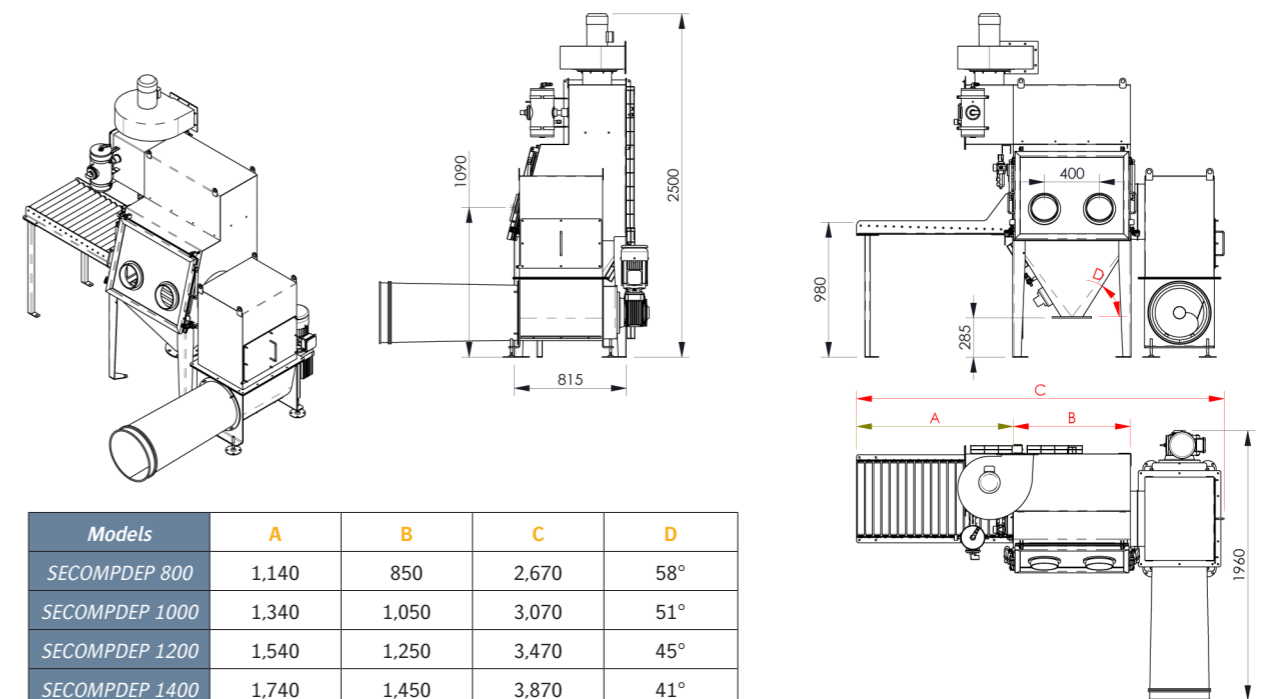

Models	A	B	C	D
SECOMPDEP 800	1,140	850	2,670	58°
SECOMPDEP 1000	1,340	1,050	3,070	51°
SECOMPDEP 1200	1,540	1,250	3,470	45°
SECOMPDEP 1400	1,740	1,450	3,870	41°

Sacktip® Hygienic : Manual Bag Dump Station

Integrated Sieve

AVAILABLE
CUSTOM
MADE

Sacktip®
Hygienic

Standard Model SH 800
Possibility of customization

Rate: 2 to 4 sacks/min.
Objective: protection

OBJECTIVES

- Protection of your process
- Prevent contamination
- Quality of your production

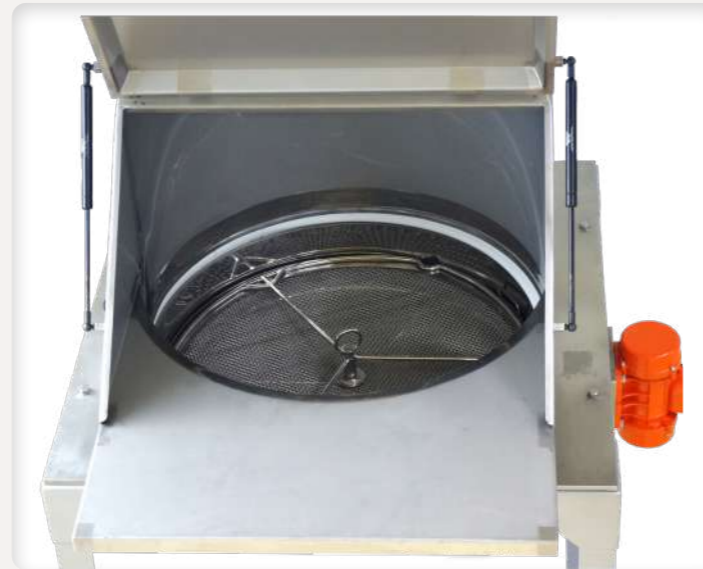

MANUFACTURING

Structure and parts in contact with the material: mild steel, 304L stainless steel, 316L stainless steel
Access door: plexiglass, antistatic lexan, tempered laminated glass
Sealing: EPDM, NBR, natural rubber
Finishes: customized RAL, peening, electropolishing



Solution for hygienical process



Customized and interchangeable screen mesh

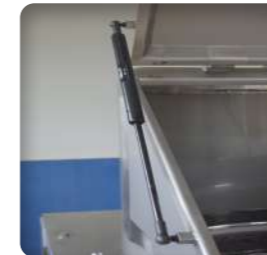

Gas cylinder to optimize the ergonomics and to support the door



(1) Mirror polish finish - (2) Rounded corners



Vibratory motor to improve the amplitude and intensity of the screen. These settings are adjustable depending on the flowability of the material and the mesh

Advantages



OPERATION



Integrated sieve: protection against foreign bodies for a production without any impurities.

EASY HANDLING



Easy access to the sifter including the screen mesh. Its design allows operators to clean and replace the screen mesh in seconds.

Options



Gloves



Vacuum sacks lifter

Sacktip® Hygienic: Manual Bag Dump Station — Integrated Sieve

Standard Model: SH 800

MANUAL BAG DUMP STATION - SH 800

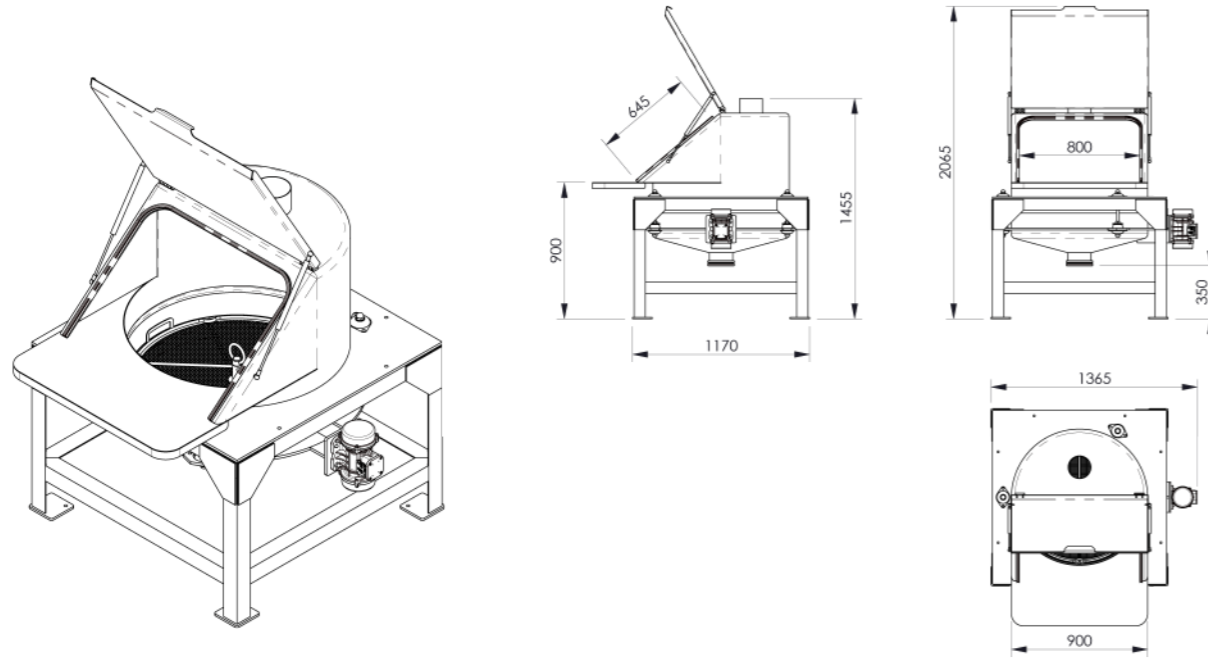

OPTION: DUST COLLECTOR - SHDEP 800

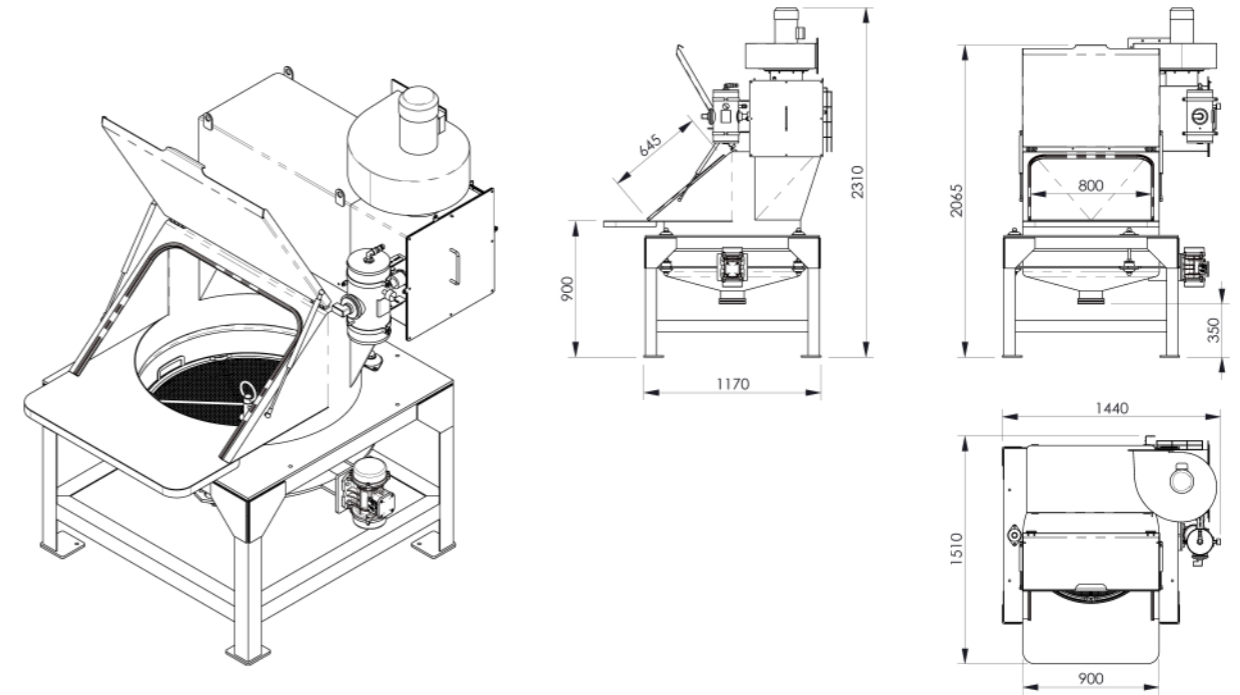

OPTION: COMPACTOR - SHCOMP 800

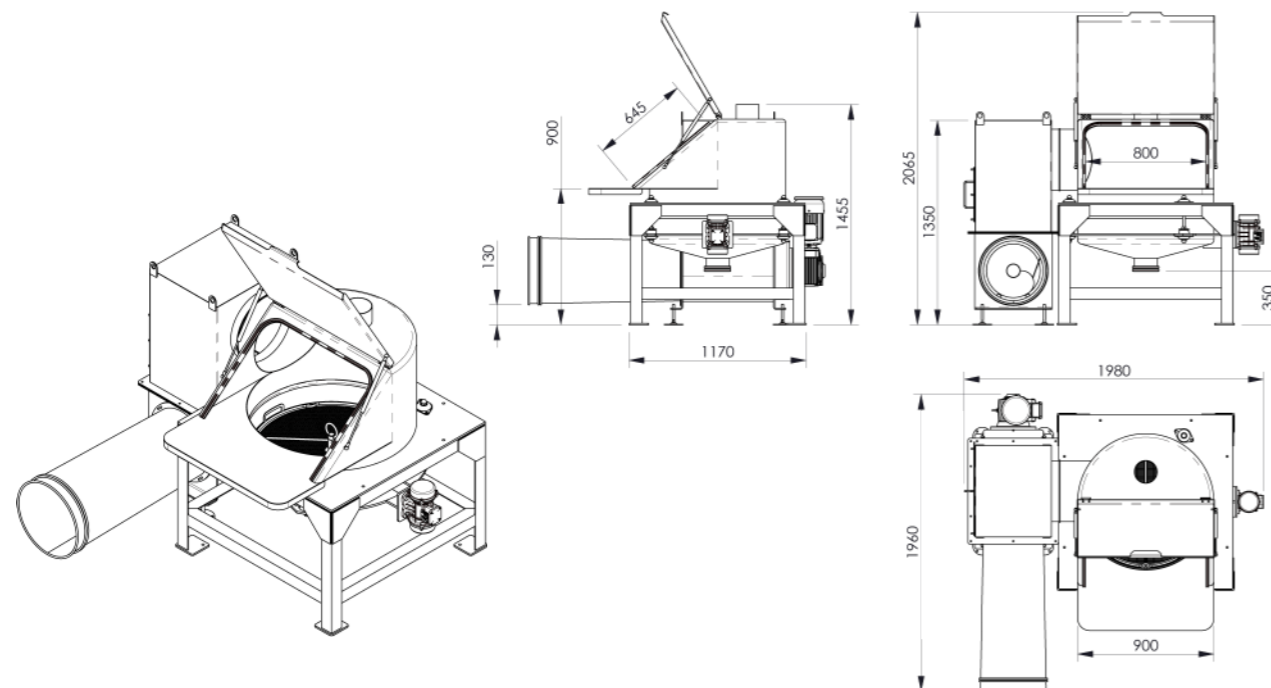

OPTIONS: COMPACTOR AND DUST COLLECTOR - SHCOMPDEP 800

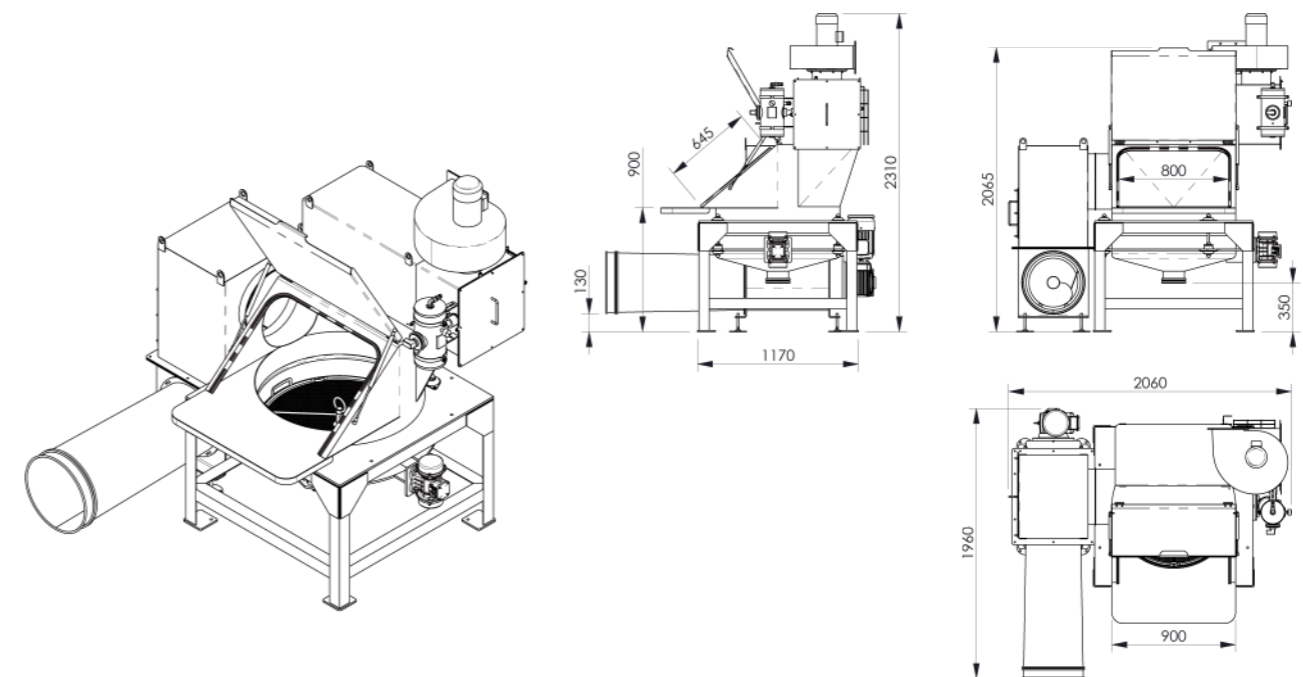

Manual Bag Dump Station Custom Made



Custom Made

Painted steel, 304L stainless steel, 316L stainless steel manufacturing

The PALAMATIC PROCESS engineering office offers customized solutions for your sack opening process according to your layout and flow constraints. We define together the adequate solution after visiting your site and following your needs and technical conditions.

POSSIBLE FEATURES

- Specific and reduced dimensions
- Applications for toxic materials
- Nuclear industry
- Advanced containment
- Manufacturing specific to the bulk material and work environment: steel, stainless steel, Hastelloy, Uranus B6, Viton, Perbunan, Nitrile...
- Surface treatment adapted to your powders: electropolishing, mirror polished, vulcanization, teflon
- Process features integration: dosing, screening, milling, granulation, anti-bridging device, mechanical conveying
- Ideal design for all types of bags
- ATEX...

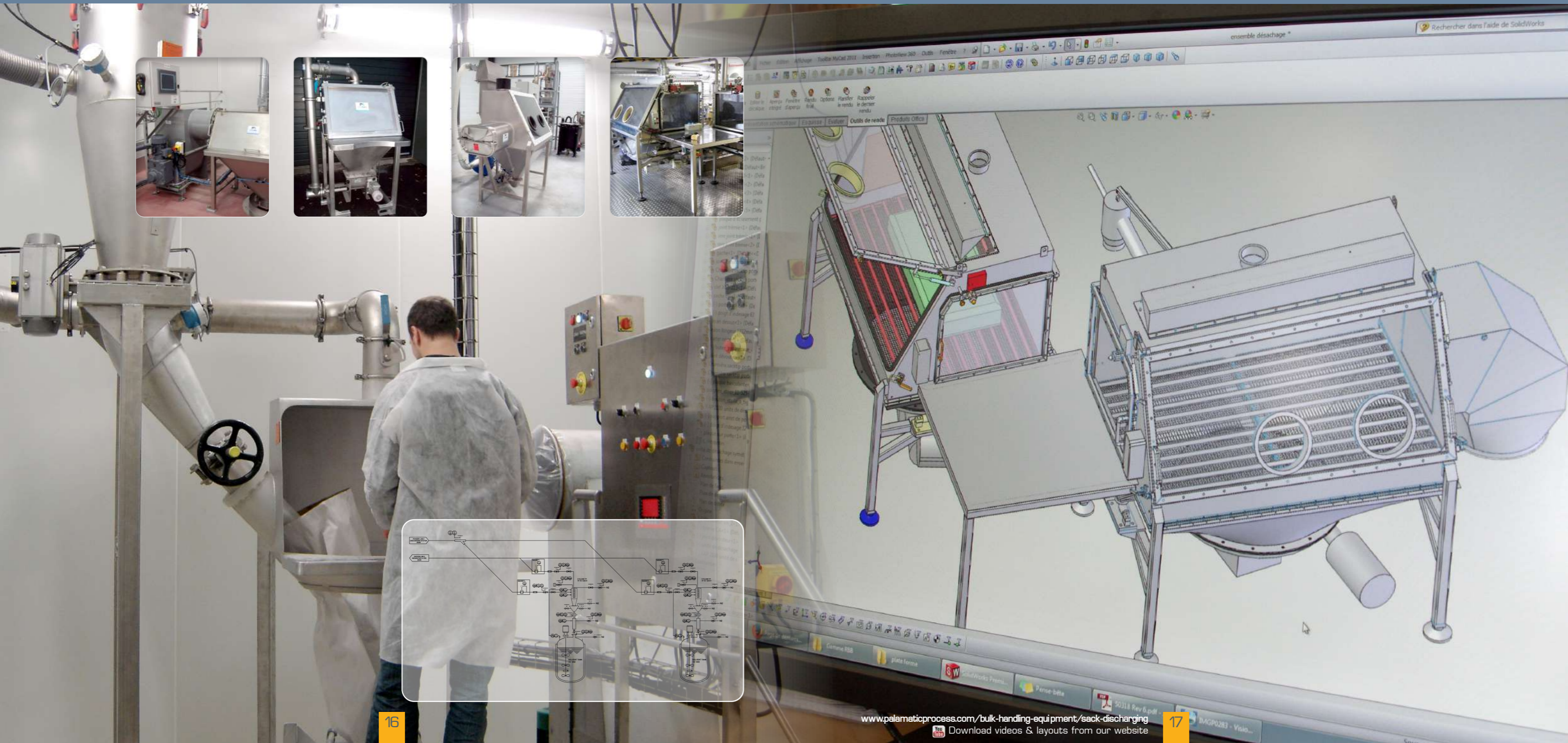



➤ VACUUM SACK LIFTER

Easy lifting and handling of the bag.

The manipulator provides the operator with maximal working ergonomics. The problem of load handling is fully resolved with the introduction of this equipment. The manipulator is suitable for all types of bags (materials and weight).



➤ GLOVE BOX

It optimizes containment and enables the handling of toxic materials.

The gloves are set on the door and mounted on PVC glove ports. Spring clips provide containment and closing. A neon facilitates opening operations through the plexiglass. The glove box is designed to allow opening and dumping of the bag and sack contents in a confined environment. The operator is protected from any contact with potential hazardous bulk materials. Also, it prevents the bulk material from contamination or interaction with the outside environment.



➤ MAGNETIC BARS

It guarantees the hygienic process by eliminating foreign substances.

The magnetic bars, installed on the dumping system, preserve the quality of materials brought into your process. The strong magnetic power capacity (13,000 Gauss) can capture the sub-millimeter particles.



➤ BELT CONVEYOR

To provide buffer storage upstream of the unloading system.

The conveyor belt allows operator to make a buffer storage of sacks to optimize the discharge cadences. The layout length and configuration are custom-manufactured to suit your needs and your constraints on site.



➤ WEIGHING - DOSING

To monitor the quantity of the loaded powder, the unloading hopper can be mounted on load cells.

Number of cells: 4
Weighing accuracy: < 1kg
Implementation: shock absorber + anti-failover device
Input signal 4-20 mA
Possible profibus communication + RS 232 + Ethernet



➤ CIP

Rotative cleaning nozzles/heads - Clean In Place (CIP).

To ensure the material change without cross-contamination, the washing nozzles are located inside the unloading unit.
Pressure of washing nozzles: 3 bars
Technology: fixed or rotating 360°
Centralized wirings and connection to the network with a clamp system.



➤ VIBRATORS / VIBRATING BIN AERATORS

They facilitate the flow and discharge of stored materials.

These vibrators transmit multi-directional vibrations to the walls, while the vibrating bin aerators combine a fluidization effect against the inner walls of the hopper. These devices allow proper flowing of your bulk materials. They help break vaults or chimneys and greatly reduce retention.



➤ AUTOMATIC CUTTING SYSTEM FOR SACKS

This system ensures maximum ergonomics and safety by preventing the operator from cutting and turning the bag.

A blade actuated by a pneumatic cylinders penetrates the bag through the grid. The operation is secured with a safety switch fitted on the door or with hand control.



➤ LUMP BREAKER

Our lump breakers are the ideal solution to crush materials that tend to form lumps.

Your materials stored in bags may tend to make lumps during storage. It is then sometimes imperative to standardize the powder particle size in order to allow its use in the downstream process, such as pneumatic conveying or introduction into a reactor or a mixer.



➤ SACK COMPACTOR

Protect the operator against potential exposure to dust during unloading.

The PALAMATIC PROCESS sack compactor enables reducing of the waste volume and maintains healthy, dust-free environment. It can be mounted on one of the hopper sides. The compacted sacks are contained within a polyethylene sheath (up to 60 sacks/m. - depending on the size and type of sacks). It may be positioned on the left, on the right or at rear of the unloading unit, with three possible positions for each of these orientations.

Sack Compactor



All Types of Sacks

Compression ratio: 60 sacks/min.*
*Depending on the type of bag

OBJECTIVES

Contain dust and minimize dust volume.



TECHNICAL SPECIFICATIONS

The compacting screw "pushes" the empty bags inside the dust-proof sheath. With an efficient and compact design, the compactor is suitable for all types of bags (paper, polyethylene, plastic, woven plastic, hessian bags...)

Characteristics

- . Mild steel, 304L stainless steel, 316L stainless steel
- . Motor 2.2 kW (direct coupling)
- . Applied bearing

A polyethylene sheath positioned at the end of the compacting tube allows to collect the empty bags at the output of the compactor. The tensioning ring of the sheath permits a completely dust-proof compression of the bag fragments. A dedusting nozzle optimizes the cleanliness of the work station. The compaction takes place in a completely confined area.

Example of integrated sack compactor



Examples of possible positionings

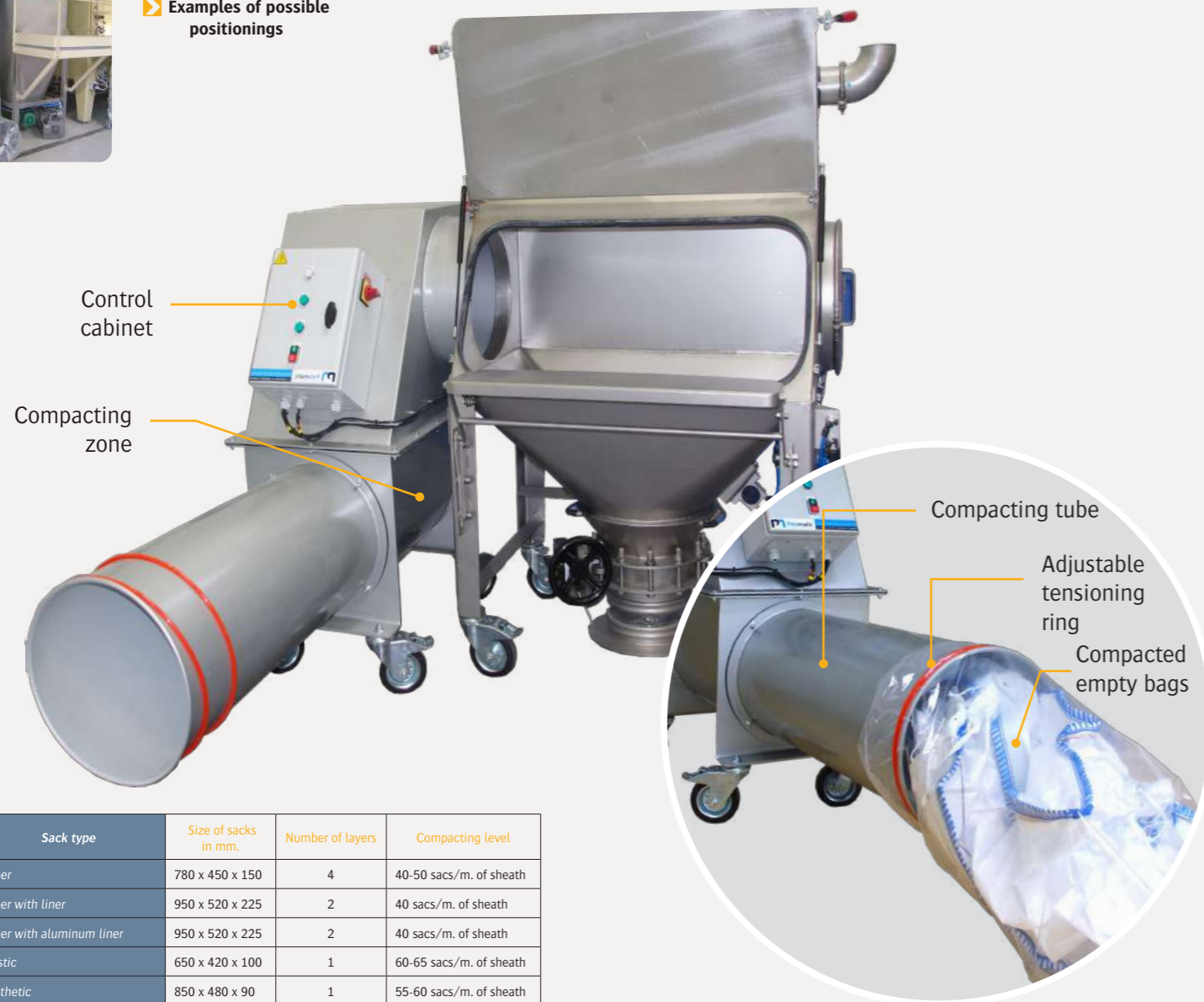

Sack type	Size of sacks in mm.	Number of layers	Compacting level
Paper	780 x 450 x 150	4	40-50 sacs/m. of sheath
Paper with liner	950 x 520 x 225	2	40 sacs/m. of sheath
Paper with aluminum liner	950 x 520 x 225	2	40 sacs/m. of sheath
Plastic	650 x 420 x 100	1	60-65 sacs/m. of sheath
Synthetic	850 x 480 x 90	1	55-60 sacs/m. of sheath
Synthetic with liner	850 x 480 x 90	2	50-55 sacs/m. of sheath
Hessian	950 x 510 x 170	1	30-35 sacs/m. of sheath
Double layer hessian	950 x 510 x 170	2	20-25 sacs/m. of sheath



- ▶ **Compacting screw**
- ▶ **Handling wheels** for mobility of the equipment (optional)
- ▶ **Ergonomic access for the operator:** the height is appropriate and it is possible to integrate a platform
- ▶ **100 % hermetic containment sheath,** clean working environment and possibility to recover residual fines by specific tray

Advantages



2 VERSIONS



INDEPENDANT COMPACTOR



INTEGRATED COMPACTOR

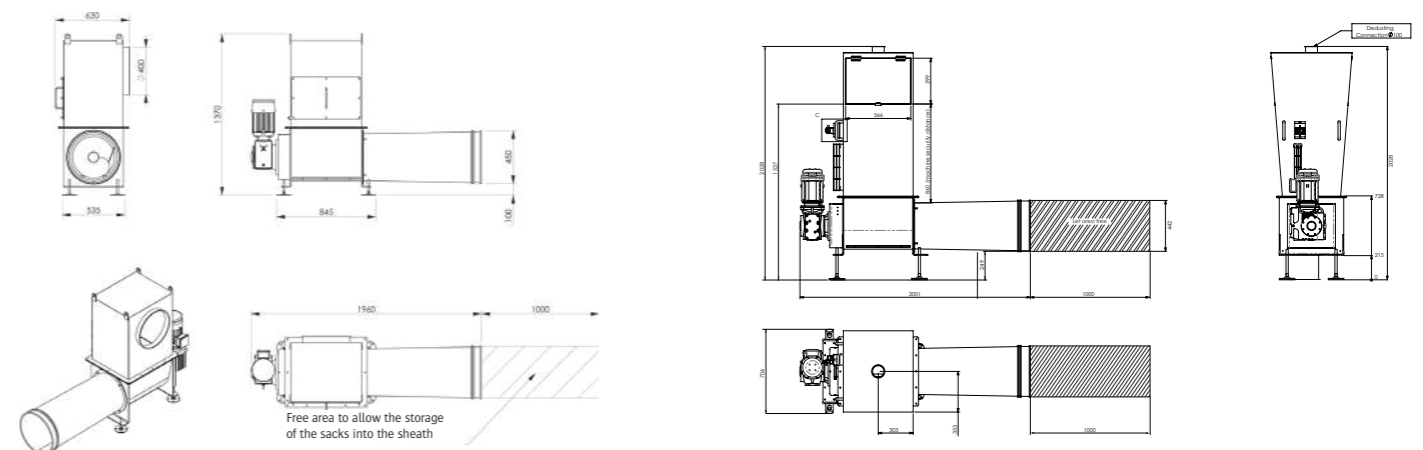

Vacuum Sack Lifter

Ex AVAILABLE CUSTOM MADE

Vacuum Sack Lifter

All Types of Sacks

OBJECTIVES

Effortless vacuum lifting of all types of sacks from 10 to 80 kg and increased productivity. It is a simple and reliable means for one operator to handle sacks from 10 to 80 kg.

Advantages :

- Effortless lifting
- Maximum performance and productivity
- Optimal working conditions
- Improvement in ergonomics
- Increased operator safety
- Very little maintenance required

EXAMPLES OF INSTALLATIONS

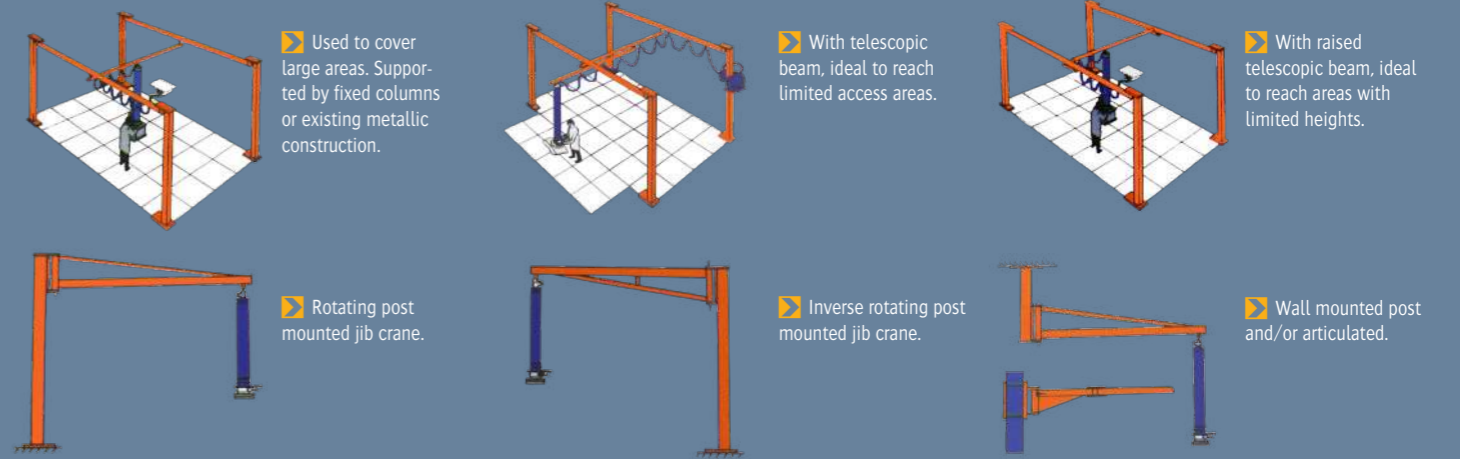

Triangular post mounted jib crane to provide a lifting stroke of 1,700 mm (overhead room 3m.)

Suction tube

360° rotation lifting tube

Lifting head

Large suction foot

Sack dumping unit



▶ Palletising: vacuum sack lifter with conveyor



▶ Vacuum sack lifter: fitted with a control handle equipped with a stay-put lever valve allowing a self-stabilization of the load at any height, without any adjustment. Ergonomic handle design, preventing wrist elongation



▶ Rubber bale



▶ Hessian bags: vacuum spike gripper to lift sacks of grains

Advantages

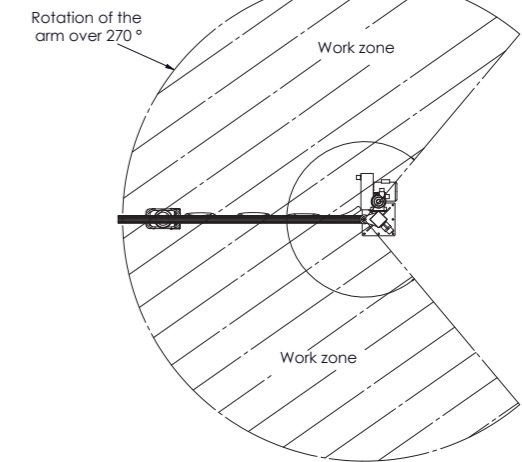
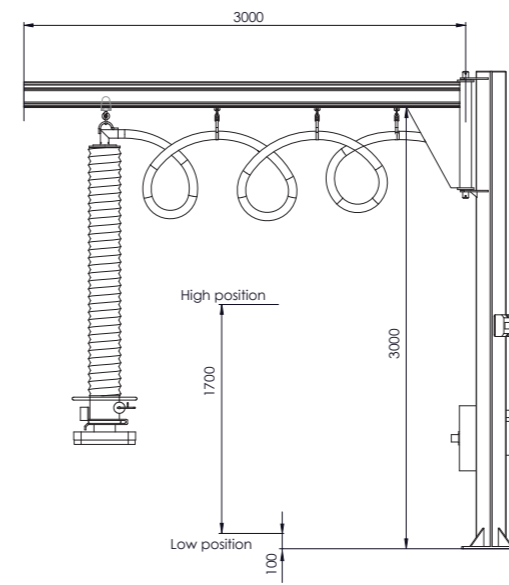

Options



Protection cover



Oversized filter for dusty bags

Suction Booth



Rate: 200 to 2,000 m³/hr.
Installation: ground, table, wall
Objective: to ensure good distribution of the suction flow around the workplace

ERGONOMICS AND SAFETY OF THE WORKSTATION

The operators working directly with powders, especially during packaging or unloading phases, have to work in a dusty environment. The suction booth is used to create a vacuum flow in the working area. The side screens enable to close the working area and to minimize the draughts effect. Our standard range of suction booths can be customized to meet your requirements.

TECHNICAL SPECIFICATIONS

Working width: 800 to 2,000 mm.
Manufacturing: mild steel, 304L stainless steel, 316L stainless steel
Finishes: 9006 RAL, bead blasted, electropolished
Frontal panels: 1, 2 or 3 panels
Air rate reached in open areas: 0.6 to 1 m./s.
Air rate reached in dedusting piping: 25 m./s.
ATEX grounding clamp
Weight: 10 to 50 kg



Adjusting flap

Slot for distribution of the aspiration

Protection of the working area



Suction booth on table



Suction booth with integrated scale

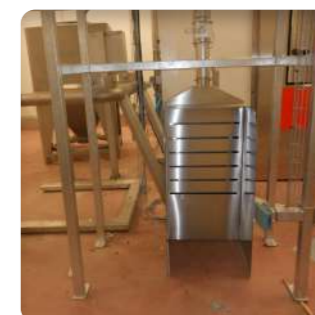

Suction booth for racking

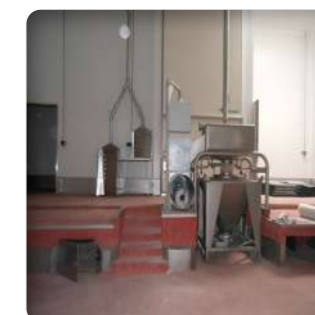

Room for pre-weighing

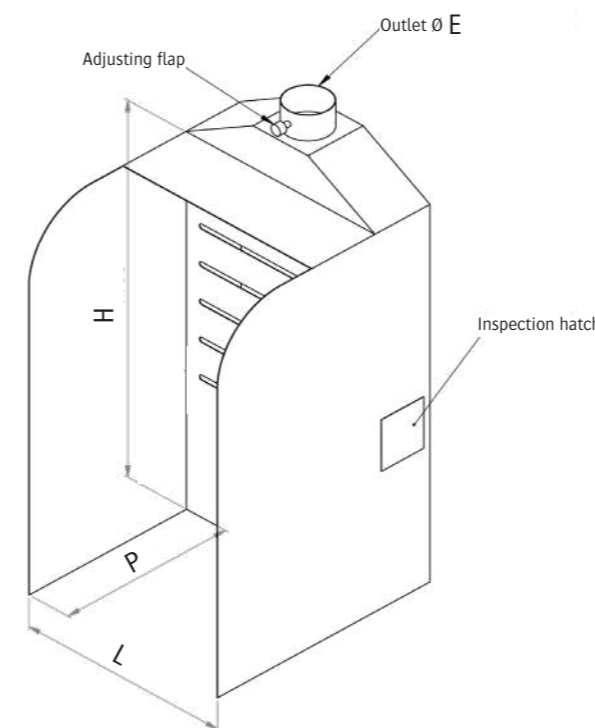

ANDEP	Dimensions	Ø E
800	L 800 x P 800 x H 1,350	Ø 200
	L 800 x P 1,000 x H 1,600	
1 000	L 1,000 x P 800 x H 1,350	Ø 250
	L 1,000 x P 1,050 x H 1,650	
1 200	L 1,200 x P 800 x H 1,350	Ø 250
	L 1,200 x P 1,100 x H 1,650	
1 500	L 1,500 x P 800 x H 1,350	Ø 300
	L 1,500 x P 1,100 x H 1,700	
2 000	L 2,000 x P 800 x H 1,350	Ø 300
	L 2,000 x P 1,100 x H 1,700	

Options



Sack unloading unit with dedusting panels



Small packagings skid set up

See all our options on pages 18-19

Pouyès Ring



Rate: 150 to 400 m³/hr.
Installation: reactor, tank, drum..
Objectives: facilitate unloading of small packings without any dust emission

ADVANTAGES

- No obstruction of the working area, direct access for loading
- Protection against dust emission
- Rapid connection to all types of equipment, removable and cleanable system

TECHNICAL SPECIFICATIONS

Dropping area for the bag: 200 to 400 mm. depth, 400 to 600 mm. width
Manufacturing: painted / galvanized steel, 304L stainless steel, 316L stainless steel
Finishes: 9006 RAL, bead blasted, electropolished
Coverage of the vacuum area: 270° to 180°
Inclination of the ring: 0° to 20°
Connection to suction device: DN50 to DN80
Connection to equipment: PN 10 Flange, clamp
Air rate reached in open areas: 0.6 to 1 m./s.
Air velocity reached in dedusting piping: 25 m./s.
ATEX grounding clamp
Weight: 10 to 50 kg



▶ **Simplified ring** for suction on the periphery of a vertical mixer vertical

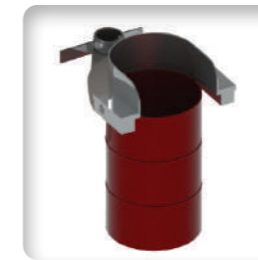

▶ **Clamping ring** for drum filling



▶ **System connected directly to the reactor** for introducing raw material. The system is removable for pressurization of the reactor



▶ **Dedusting of the working area**

Advantages



EXAMPLES OF INSTALLATIONS

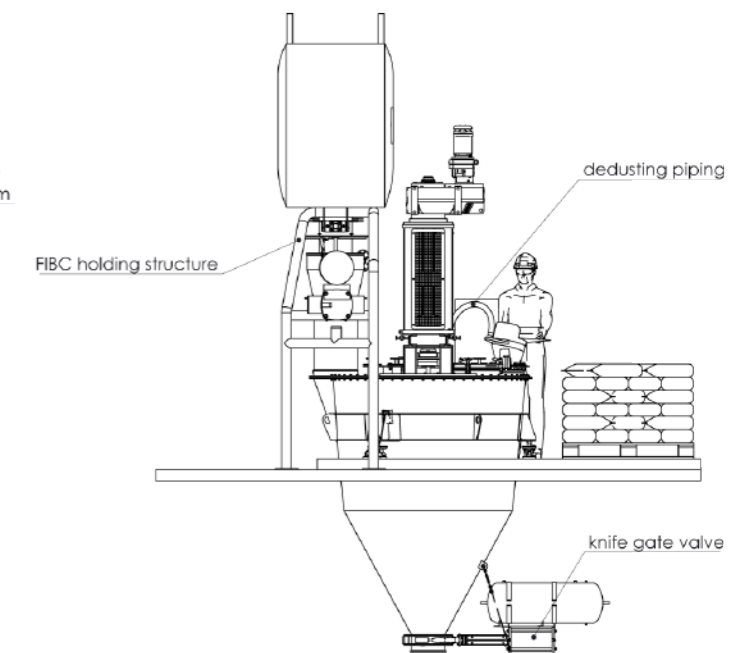
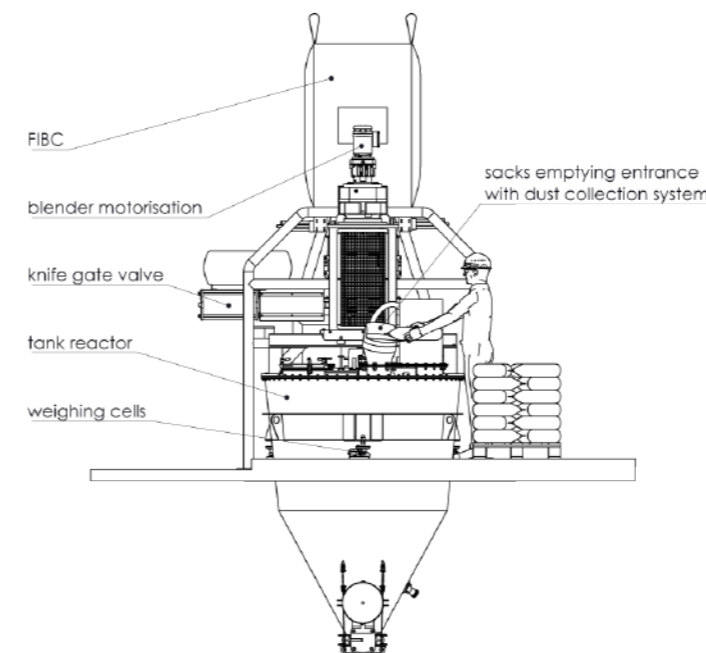

Semi-Automatic Bag Dump Station

AVAILABLE
CUSTOM
MADE

Ergotip®

Ergotip®
Patented system

Rate: 6 sacks/min.
Capacity: 15 to 50 kg/sack
Manufacturing: mild steel, 304L
stainless steel, 316L stainless steel

SACK UNLOADING OF VARIOUS SIZES

The ERGOTIP® sack opening system is used in all industries. The articulated blade provide a clean cut to all types of sacks. The two-handed control system ensure a safe and efficient operation, as well as a faster rate of emptying bags.



TECHNICAL SPECIFICATIONS

The drive mechanism is positioned outside the equipment to avoid contact with the dry materials.

- Suitable for many types of bags: paper, polywoven, lined...
- Minimizes operator handling of the bag
- Increased productivity
- Airborne dust is drawn into the dust collector, preventing plant contamination
- Integrated sack compactor
- Easy to clean

Advantages



- ▶ **Integrated sack compactor**
- ▶ **Integrated dust collector**
- ▶ **Pneumatic cutting cylinder** with accumulator for optimal cutting
- ▶ **Holding bar**

OPERATING SEQUENCE



- ▶ **The operator places the sack on the safety grate and uses both hands to actuate the controls for the cutting blade.**
- ▶ **The blade provides a clean cut to the bottom side of the bag.**
- ▶ **The operator folds and shakes the sack to release the material with minimal effort.** The operator does not have to turn the bag over.
- ▶ **The material is poured into the hopper below.**

OPERATING PRINCIPLE

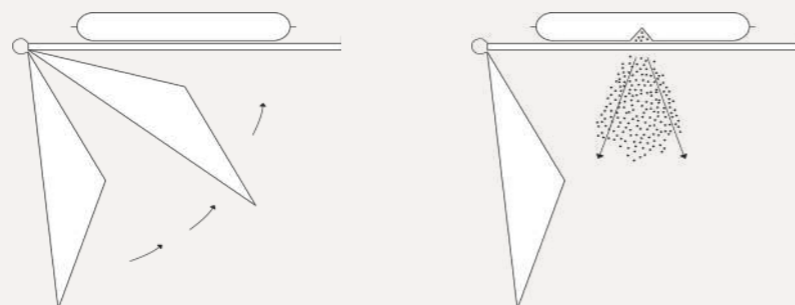

- ▶ **The cutting blade** punctures the bottom of the bag which reduces the required amount of handling by the operator. This blade improves both the ergonomics and feed rate of the workstation.

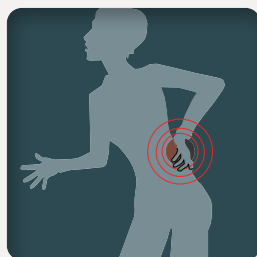

- ▶ **The ergonomic position of the operator is effective and safe.** The amount of bag handling is minimized, significantly reducing the risk of injury to the operator.

Automatic Bag Dump Station



SAS®

SAS®
Patented system

Rate: 2 to 4 sacks/min.
Capacity: 15 to 50 kg/sack
Manufacturing: mild steel, 304L stainless steel, 316L stainless steel

SEMI-AUTOMATIC SYSTEM, OVERALL DIMENSIONS REDUCED

To establish a connection between manual and automatic bag dump stations, PALAMATIC PROCESS offers a semi-automatic machine. This equipment is ideal for food, pharmaceutical and chemical applications. This machine is intended for semi-automatic opening of any type of sack (except aerosils), limiting the operator's movement to set up the bag. The degree of dust containment of the machine that operates with the closed door, the installation of a sack compactor and the connection to the dedusting piping minimize fine particles emission in the atmosphere (a dust collector can be proposed as an option). It guarantees operation in a dust-free environment, without the need of cutting the sack manually. The machine is supplied with a complete control cabinet to ensure the rate you require.

TECHNICAL SPECIFICATIONS

1. The blade pivots from the back to the groove provided in the screen and cuts the bottom of the sack
2. The blade retracts and the material flows into the hopper
3. The bars do the shaking to make the material come out of the bag
4. The bag ejector bar sends the empty sack into the compactor

ADVANTAGES

- Pneumatically controlled cutting system that leaves hands free
- Ideal solution for hazardous areas



▶ **Internal mobile parts** of the machine ensuring the shaking and the ejection of the sacks



▶ **External actuator**



▶ **Screw compactor** for the evacuation of the emptied sacks and the reduction of dust emissions



▶ **Ejection** of empty bags into the compactor

Advantages



OPERATING PRINCIPLE

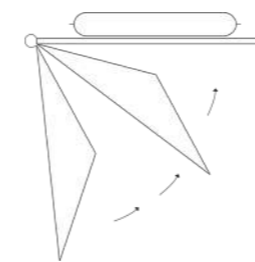

1. Articulated cutting blade

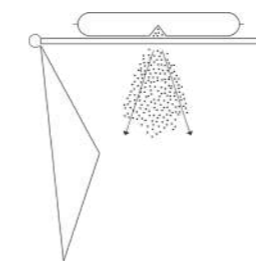

2. Programmable cutting cycle

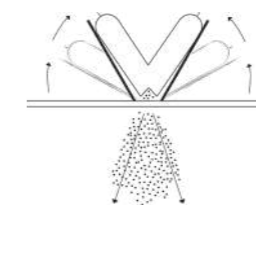

3. Shaking of the sack with articulated plates

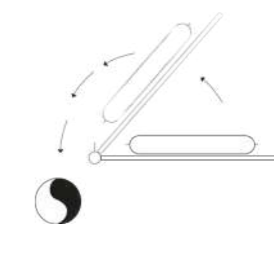

4. Ejection of the emptied sack to the compactor

Options



Sack lifter



Rotative cleaning nozzles/heads - Clean In Place (CIP)

See all our options on pages 18-19

Automatic Bag Dump Station



▶ GENERAL LAYOUT

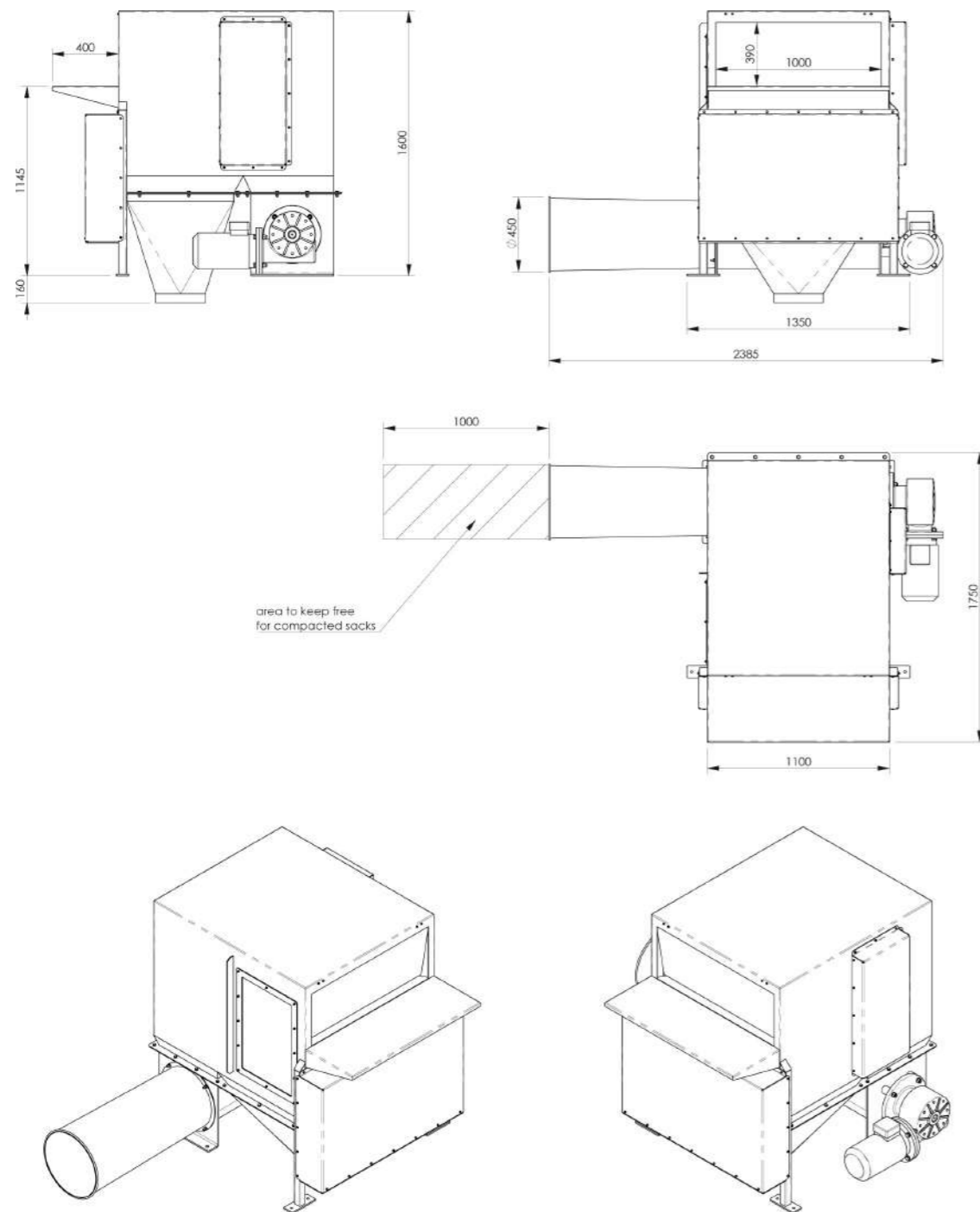

The SAS® bag dump system allows, due to its mode of operation, deconditioning of explosive material with a very low or low EMI. The moving parts included in the SAS provide slow speeds, thus avoiding the risks of sparks caused by impacts.

Electrical continuity of all the parts ensure safe operation. The dust collector offers maximum dust containment in an ATEX zone. Also, the bag opening is carried out when the door is closed: no external ATEX risk.



Automatic Bag Dump Station



Minislit®

Minislit®

Patented system

Rate: 8 sacks/min.
Capacity: 15 to 50 kg/sacks
Manufacturing: mild steel, 304L stainless steel, 316L stainless steel

AUTOMATIC OPENING AND UNLOADING OF SMALL SACKS AND BAGS

The Minislit® automatic bag dump station uses a ribbon cutting tool to open and unload sacks of powders and dry bulk materials. It is adaptable to varying bag sizes and can be used for applications ranging from aggregates, chemicals and food products. The Minislit® sack opening system can be cleaned manually or mechanically with optional CIP – “clean in place” system, providing a complete wash and dry process (30 minute cycle for washing and drying).

Equipment

TEST CENTER

Available



TECHNICAL SPECIFICATIONS

The band saw system creates a three-sided cut on the sack without tearing the material. The patented disc inversion system guarantees full discharge of the dry material. The Minislit® is suitable for the food, chemical and powder paint industries.

PALAMATIC PROCESS has designed this automated bag dump system to provide material unloading at higher rates with minimal operator intervention.

To minimize wear and tear, the mechanical gears and guiding components are located externally, offering versatility in material unloading operations and easy access for maintenance of parts.

ADVANTAGES

- Suitable for various bag materials: paper, poly-woven, lined, etc.
- Minimize operator handling
- Maximize production
- Reduce and eliminate dust emissions with connection to central dust system or built-in dust filter unit
- Integrated sack compactor for automatic waste disposal
- Ribbon saw is available in various options: carbon steel (high speed), stainless steel or diamond coated for abrasive material applications.

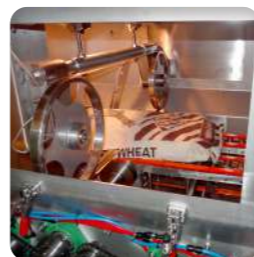

▶ The belt conveyor transports the bag directly to the ribbon-saw cutting system



▶ Vacuum sack lifter and belt conveyor



▶ Screw compactor for evacuation of empty bags into a plastic sheath and reduction of dust emissions



▶ External gearing

Advantages



OPERATING PRINCIPLE

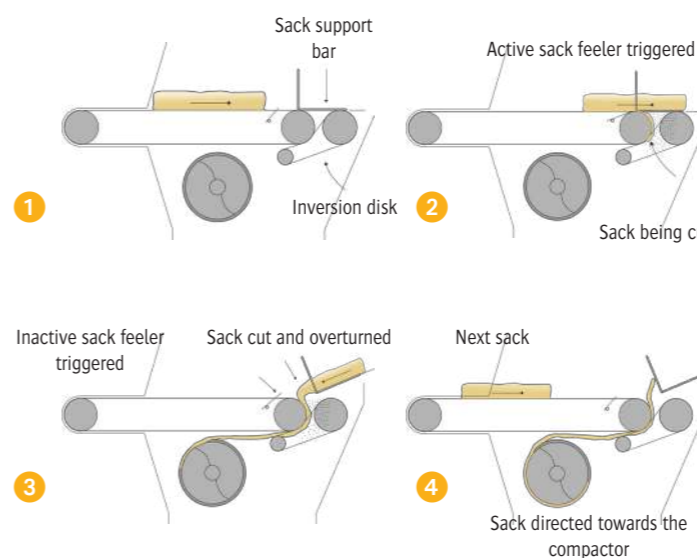

MINISLIT® THROUGHPUT CAPACITIES

PRODUCTS	Sacks per minute
Peanuts	8
Coffee beans	6
PE / LDPE granules	8
Lentils	6-8
Animal feed pellets	5
Dicalite	6-8
Sugar	4-6
Tea	5
PVC powder	4-5
Carbon black	4-6
Soya flour	4-5
Cement	5-6
Starch	4
TiO2	4-5
Aluminium oxide	3-4
Caustic flake	3-4
Ammonium sulphate	3-4
Milk powder	5-6
Filtration soil	4-5

Tilting blade system ▶



www.palamicprocess.com/bulk-handling-equipment/en-us/automatic-sack-discharging-minislit

Download videos & layouts from our website

35

Automatic Bag Dump Station

Minislit®

Patented system

Minislit®

▶ GENERAL LAYOUT

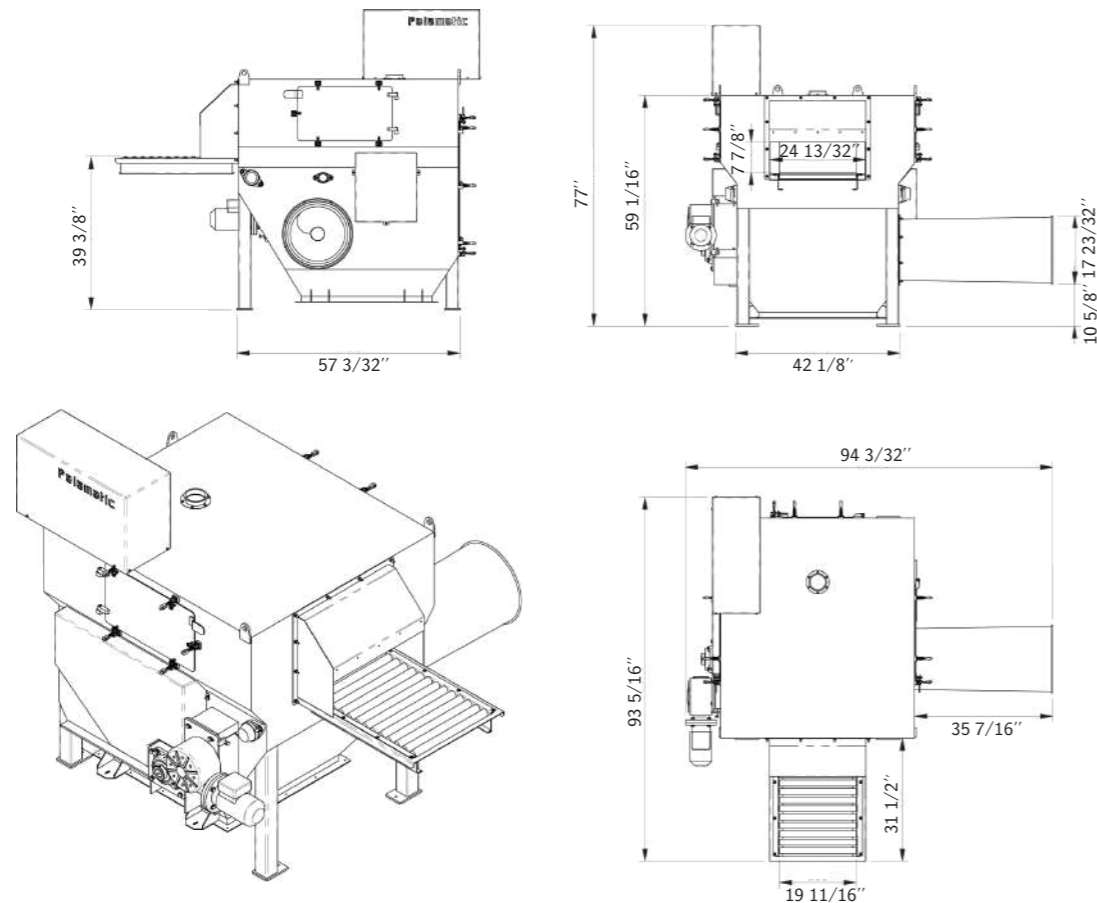

▶ EXAMPLE OF IMPLEMENTATION

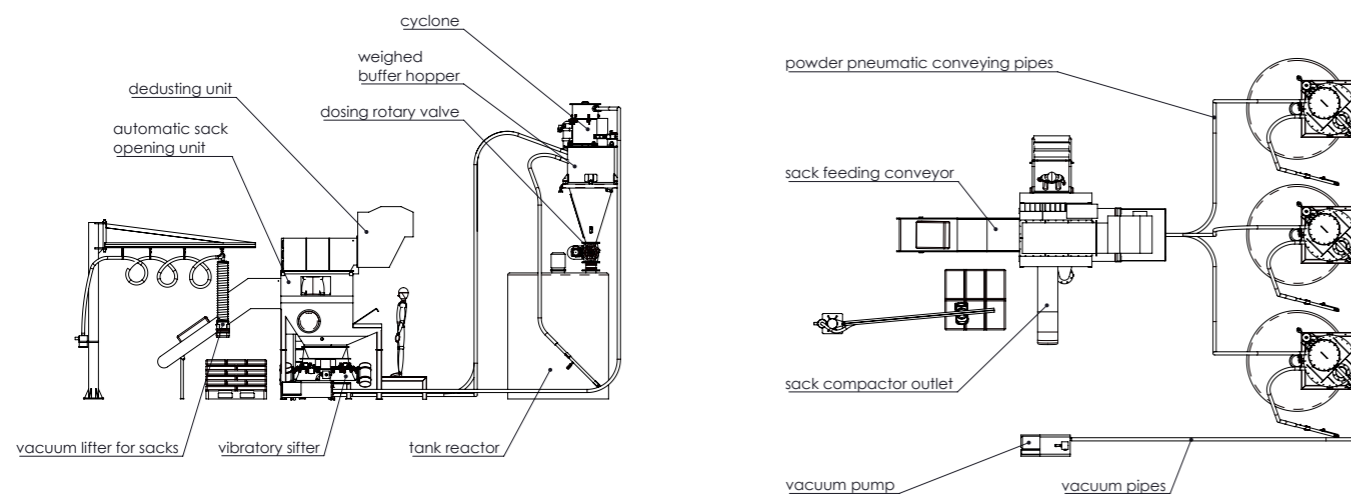

▶ OPTIONS



Vibrating spout for dosing and homogeneous separation of your bulk materials.



Dust collector system to vacuum fine particles.



Inclined conveyor to feed the unloading station.



Vacuum lifter for sacks for effortless handling and improvement of the productivity



Integrated lump breaker enables the machine to handle powders with lumps. The blades ensure the passage of the lumps through a calibrated screen.



The MINISLIT® automatic bag dump system is a part of our test center for easy testing of any type of bags.

These industrial-scale tests are a guarantee of result and success of your project.



▶ EXAMPLES OF INSTALLATIONS



▶ Application in paint industry



▶ Application in food industry



▶ Facility for seeds



▶ Application in petrochemical industry

Automatic Bag Dump Station



Rotaslit®

Patented system

Rate: 6 sacks/min.
Capacity: 15 to 50 kg/sack
Manufacturing: mild steel, 304L stainless steel, 316L stainless steel

AUTOMATIC DECONDITIONING AND ELIMINATION OF EMPTY SACKS

The ROTASLIT® opening unit is widely used in food, pharmaceutical, chemical and agrochemical industries. The bags are cut by a multi-blade shaft and transferred by the compacting screw compactor into the drum. The dust extraction option offers the best solution for rapid automatic opening of sacks with no dust. It was commissioned on platforms to facilitate the incorporation of raw materials in the process. This automatic machine uses only one 3 kW-motor.

TECHNICAL SPECIFICATIONS

The sack is conveyed by a screw to the compactor and at the same time stirred in a rotating drum. This configuration allows an optimal discharge of the bag. The greatest strength of this machine is to accept bags oriented in the length or width and the ability to process large varieties of packagings such as boxes or sacks covered with paper or plastic and plastic or paper bags. Like all the other PALAMATIC PROCESS automatic bag dump stations, its conception facilitates cleaning and maintenance with minimal retention points, flanges and gaskets. This sack opening unit can process 10 tons of material per hour (depending on the fluidity of the bulk material) and is available in steel or stainless steel.

ADVANTAGES

- Suitable for many types of bags: paper, polywoven, lined...
- Minimize the handling by the operator
- Robustness, reliability and productivity
- Can be used in areas with restricted head room
- Integrated sack compactor
- Better productivity
- Reduced dust contamination
- Easy to clean

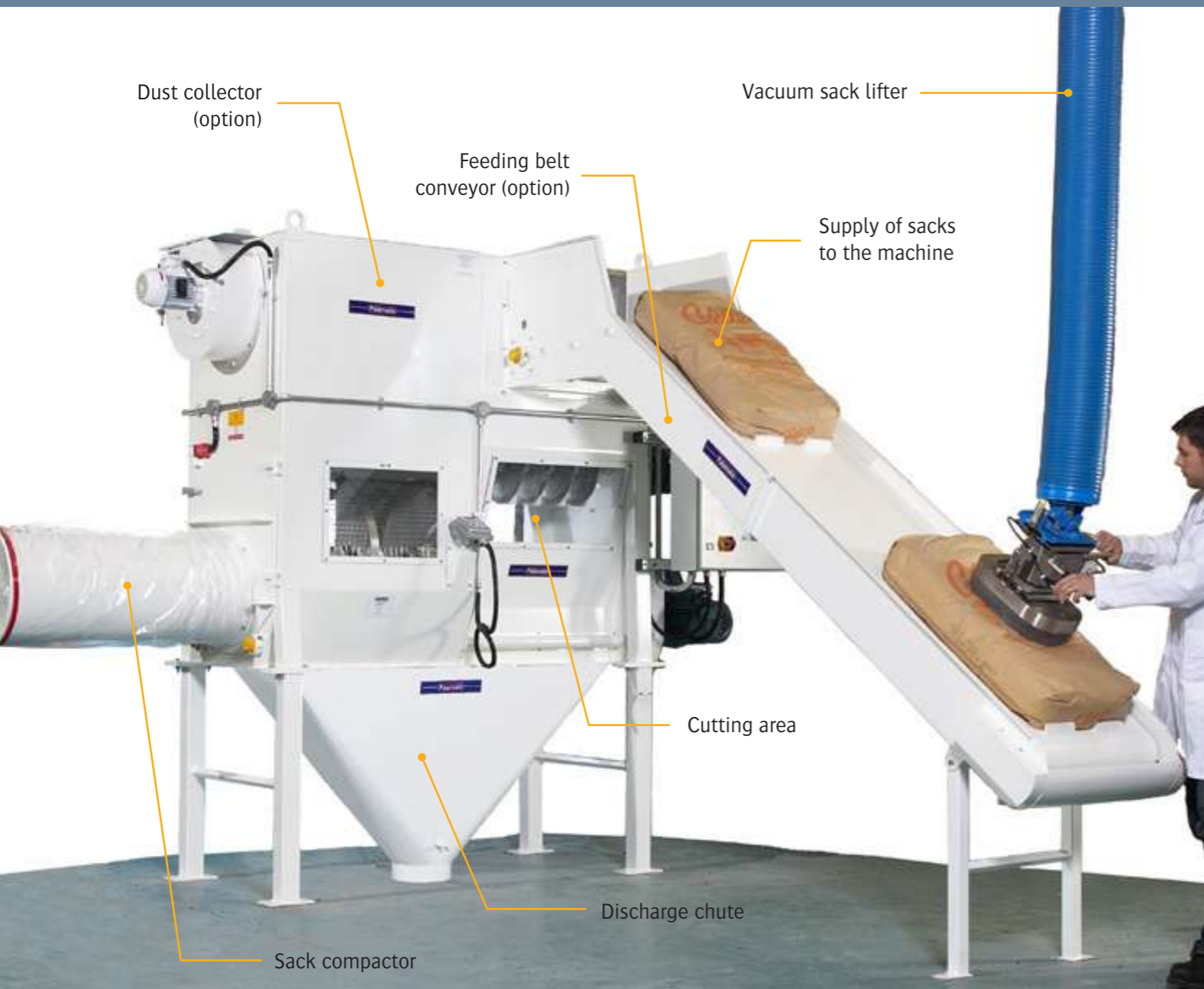

▶ Cutting system with rotating drum

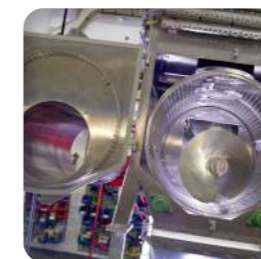

▶ Screw compactor to discharge the empty bags and to reduce dust emission



▶ Opening over the compacting screw



▶ Vacuum lifter to handle effortlessly sacks for an ergonomic working station (option)

Advantages



Inner turbine system

▶ ROTASLIT® THROUGHPUT CAPACITIES

PRODUCTS	Sacks per minute
Peanuts	6
Coffee beans	6
PE / LDPE granules	6
Lentils	6
Animal feed pellets	4
Dicalite	6
Sugar	4
Tea	6
PVC powder	3-4
Carbon black	4
Soya flour	6
Cement	4-6
Starch	3
TiO2	3-4
Aluminium oxide	4-6
Caustic flake	4-6
Ammonium sulphate	5
Milk powder	4
Filtration soil	6

Automatic Bag Dump Station



Rotaslit®

Patented system

▶ GENERAL LAYOUT

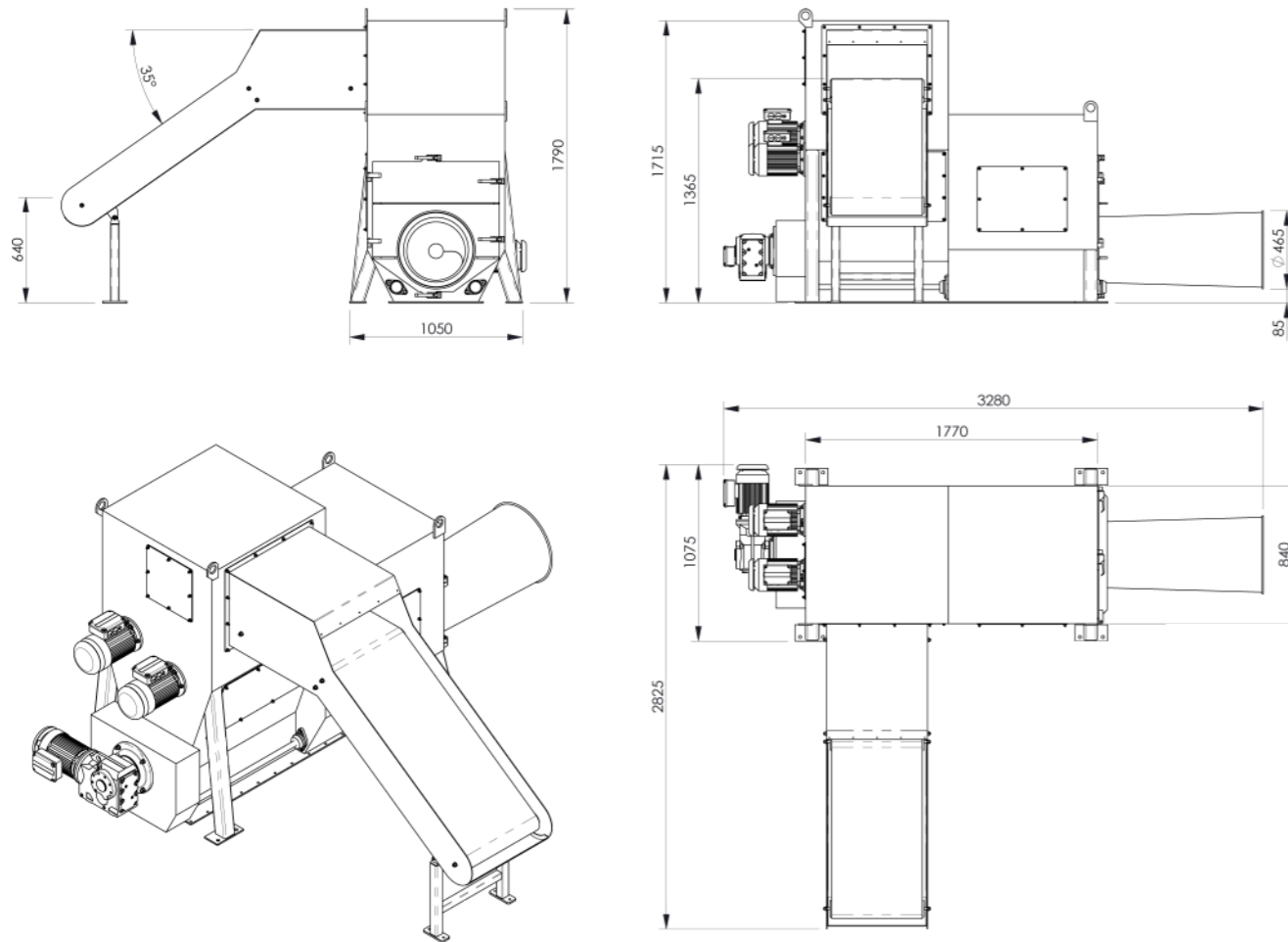

▶ EXAMPLES OF IMPLEMENTATION



▶ ATEX version



▶ Feeding of the machine with a vacuum sack lifter



▶ Rotating blades

▶ ATEX AND EXPLOSIVE ATMOSPHERE

Due to its design, the ROTASLIT® is particularly suitable for ATEX applications. ATEX configuration includes additional security organs such as temperature sensors, engine torque calculation, rotation controller. Our R&D department defines with you the system requirements depending on the products that you deal with.

▶ AUTOMATION

The automation is an integral part of the expertise of PALAMATIC PROCESS. The ROTASLIT® machine is fully driven by our automaton so the success of the raw material loading is guaranteed.

Automatons: Siemens, Télémécanique, Allen Bradley, Rockwell

▶ OPTIONS



Dust collector ensuring healthy work environment



Vacuum sack lifter for an effortless loading of the machine. The rate is guaranteed with maximum ergonomics



Support raiser for the machine to enable the operator to have access to the various doors of the machine

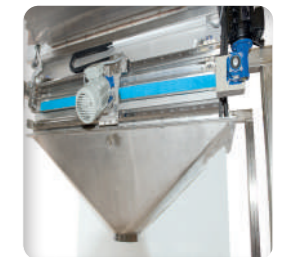

Vibrating chute allows to channel the material flow for introduction into the process downstream



Roller conveyor to feed the machine



Belt conveyor, horizontal or inclined. It integrates detection cells to adjust the flow rate of the machine

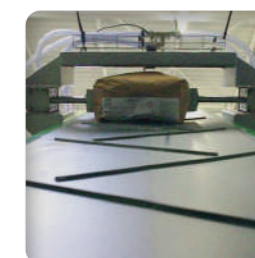

Pre-crushing of the bags when passing bags with lumps. The passage of the bag in front of the detect sensor starts the crushing action



Steel - Stainless steel manufacturing for all parts in direct contact with the handled materials

Automatic Bag Dump Station

AVAILABLE
CUSTOM
MADE

Varislit®

Varislit®
Patented system

Rate: 12 sacks/min.
Capacity: 15 to 50 kg/sack
Manufacturing: mild steel, 304L stainless steel, 316L stainless steel

TECHNICAL SPECIFICATIONS

The rotating double blade system, which is in standard version on this machine, and its elongated shape can process large bags with an extremely high rate of discharge. The entire mechanics is positioned outside to avoid any contact with the material (bulk, powders ...).

ADVANTAGES

- Suitable for many types of bags : paper, polywoven, lined...
- Minimized operator's handling
- Increased productivity
- Reduced dust contamination
- Integrated sack compactor
- Easy to clean

HIGH RATE DECONDITIONING, MULTI SACKS

The VARISLIT® automatic bag dump station is widely used in food, pharmaceutical, chemical and agro-chemical industries. Its patented inversion system ensures a full discharge of the material and the feeding of the emptied sacks into the waste sack compactor. The optional dust extraction system provides the best solution for an efficient opening without dust contamination.



▶ **Automatic cutting of the sacks** for a rapid opening and increased productivity



▶ **External gearing**



▶ **Screw compactor** to compact and discharge bags into a plastic sheath to secure the outlet of the compactor

Advantages

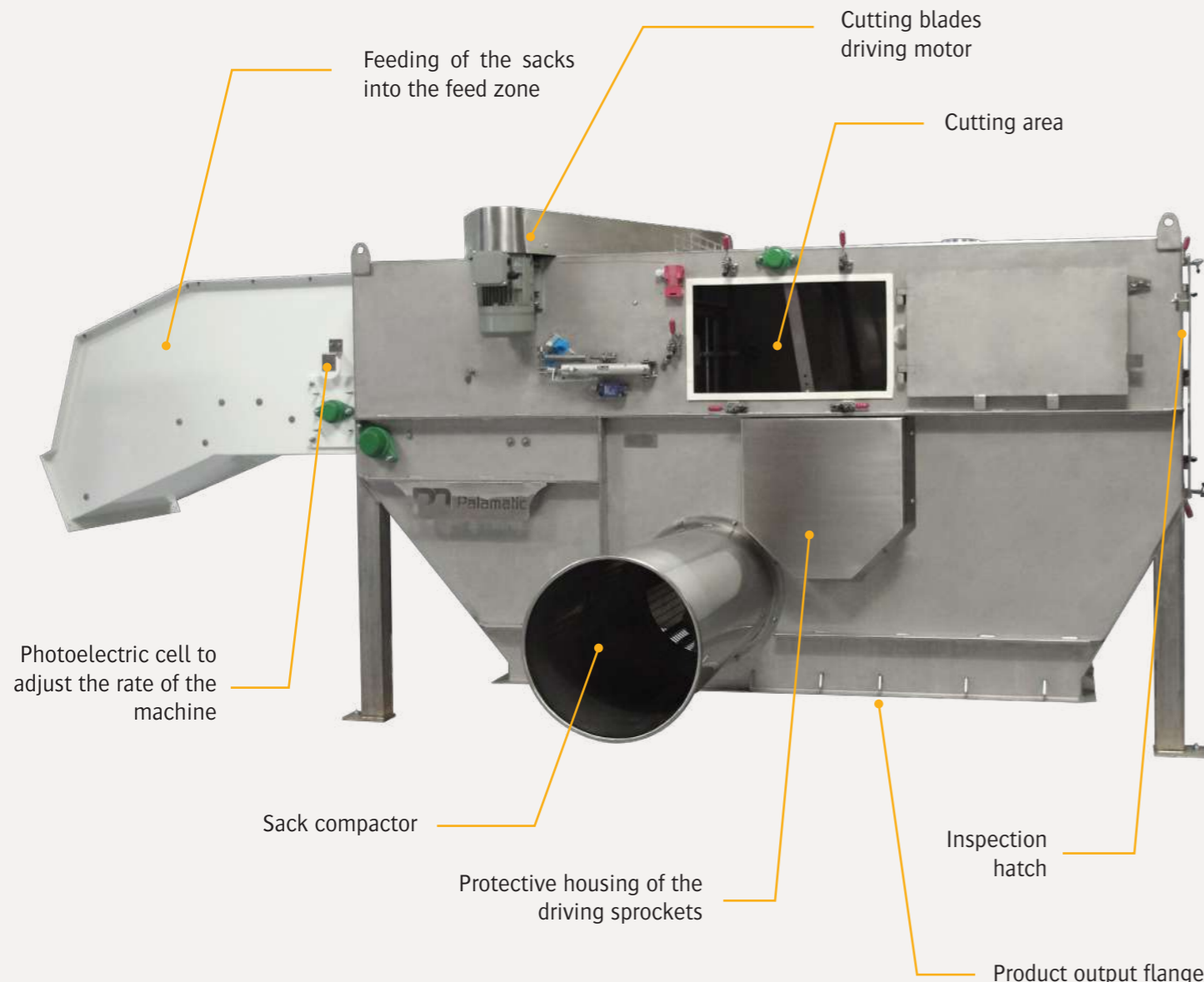

▶ **Inside view of the VARISLIT®** with the cutting system and the compacting screw



▶ **Sacks are cut on 3 sides** for a total opening and an integral emptying



▶ **Handling is made easier** for the operator and allows him to monitor the speed of the machine



▶ **Monitoring touch screen PalTouch® technology**

VARISLIT® 6000 THROUGHPUT CAPACITIES

PRODUCTS	Sacks per minute
Peanuts	8-10
Coffee beans	6-8
PE / LDPE granules	10-12
Animal feed pellets	6-8
Dicalite	8-10
Sugar	6-8
Tea	8
PVC powder	5-7
Carbon black	6-8
Soya flour	6-8
Cement	8
Starch	6
Aluminium oxide	6-7
Caustic flake	6-8
Ammonium sulphate	6-7
Milk powder	6-8
Filtration soil	6-7

Automatic Bag Dump Station

Varislit®
Patented system

▶ GENERAL LAYOUT

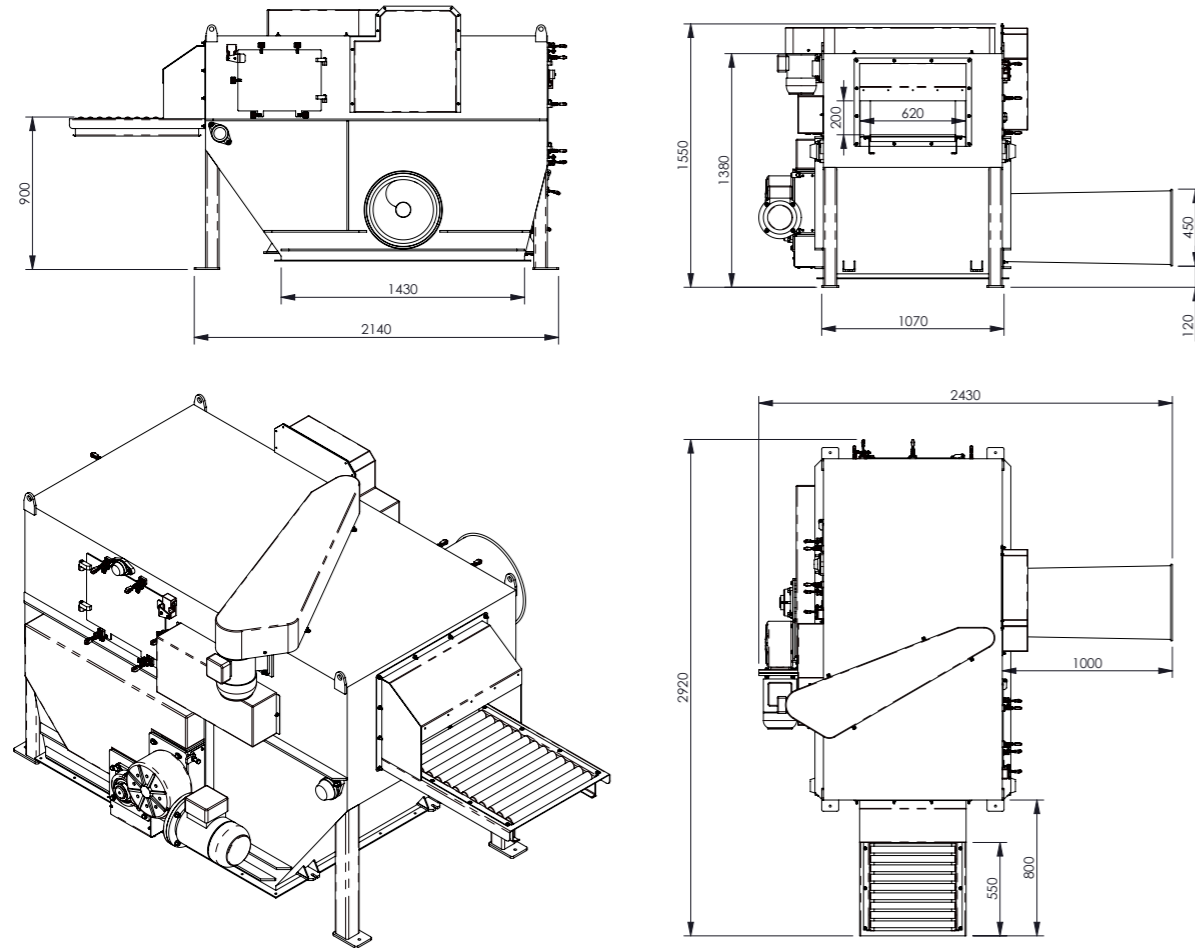

▶ OPTIONS



Hopper to add additives: pre-weighed and half sacks

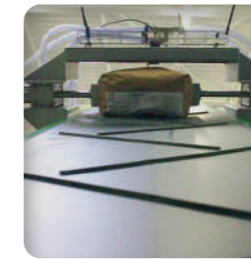

Pre-crushing of the bags during bags with lumps passage. The passage of the bag in front of the detect sensor starts the crushing action



Extended body allows to process sacks with a maximum length up to 1 200 mm

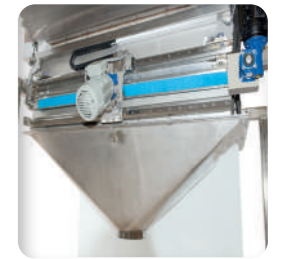

Vibrating chute allows to channel the material flow for introduction into the process upstream



Stainless steel static chute for the transfer of the powders into the process



Sack infeed conveyor allows the conveying of the sacks towards the drive belts



Holding roller to handle sacks of less than 15 kg



Steel - Stainless steel manufacturing for all parts in direct contact with the handled materials

▶ EXAMPLE OF IMPLEMENTATION

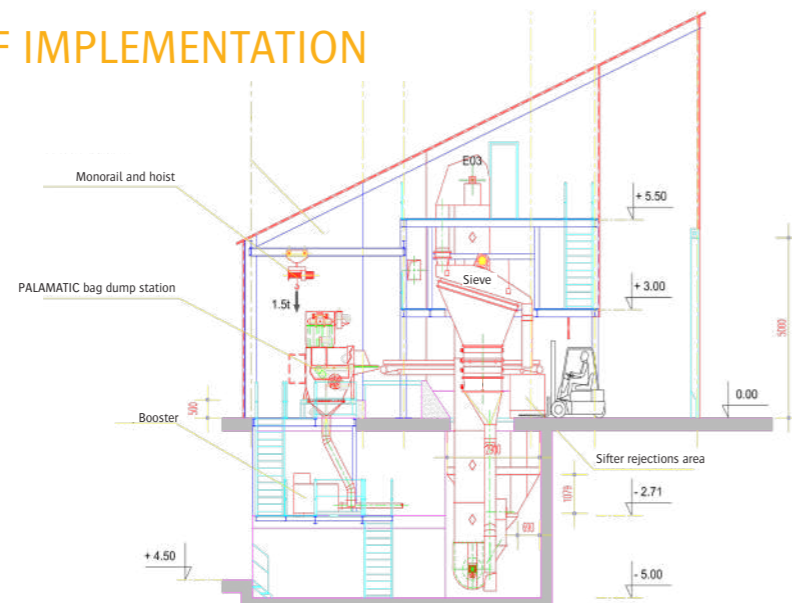

▶ PRIOR INSTALLATIONS



▶ Milk powder process



▶ ATEX zone 21 implementation



▶ Reactor feeding through a sifter



▶ Deconditioning of cement with pneumatic conveying

Automatic Bag Dump Station



Autotip

Rate: 15 sacks/min.
Capacity: 15 to 50 kg/sack
Manufacturing: mild steel, 304L stainless steel, 316L stainless steel

SACK CRACKING AT VERY HIGH SPEED

The automatic bag dump station AUTOTIP 1200 can open paper, polyethylene, synthetic and hessian sacks containing materials such as plastic granules, coffee beans, tea and rice.

This machine, the biggest of the range, is designed to open bags at the rate of 15 to 20 bags per minute (up to 60 tons per hour).

OPERATING METHOD

The bags are opened automatically using a pair of cutting blades. The material then passes through a sifter located directly below the cutting section. This system ensures that each bag is cut at least once. The material and the open bags are then transported by gravity in a rotary drum using the screw. The rotary drum ensures that the material is effectively separated from its packaging. This drum will convey empty packaging throughout its length and then supply a full screw compactor for collection of empty sacks in a polyethylene sheath. The material then flows through the screen situated directly under the rotating drum in a discharge chute (this action is carried out by gravity). To complete the operation, the operator simply presses on a stop button on the control panel.

ADVANTAGES

- Suitable for many types of bags: paper, polywoven, lined...
- Can be used in areas with restricted room
- Integrated sack compactor
- Increased productivity
- Reduced dust emissions
- Easy to clean

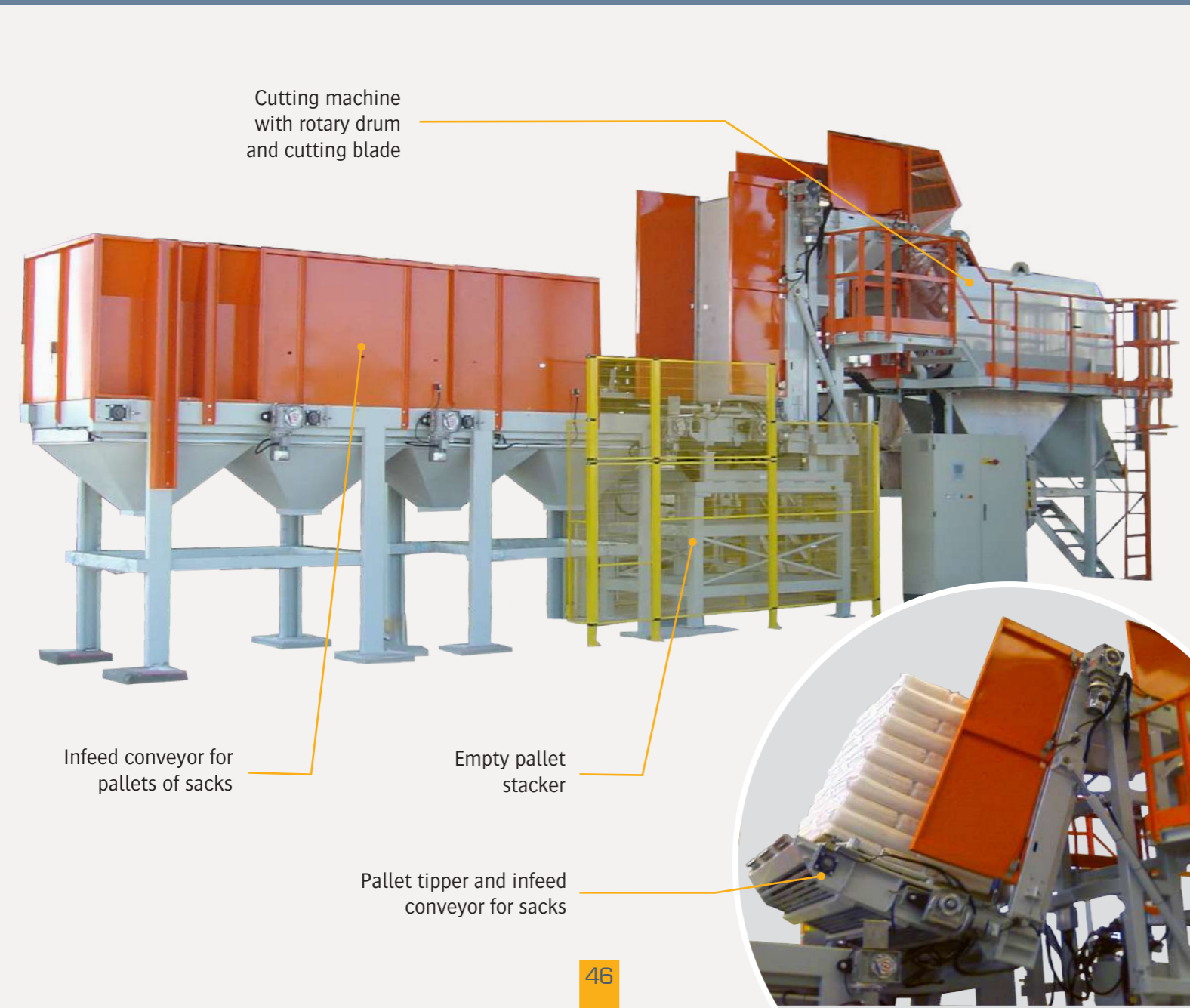

▶ **Rotative drum:** separation of powders and sacks



▶ **Types of handled sacks:** paper and polyethylene



▶ **Cutting system** with rotative drum



▶ **Vibrating chute** allows to channel the material flow for introduction into the process upstream

Advantages



FEEDING PROCESS



1 Infeed conveyor



2 Supply of full pallets



3 Tilting of the full pallet directly into the machine

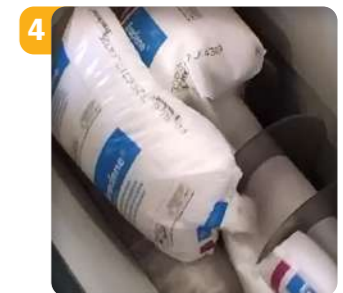

4 Pre-cutting of the sacks

Automatic Bag Dump Station

Autotip

▶ GENERAL LAYOUT

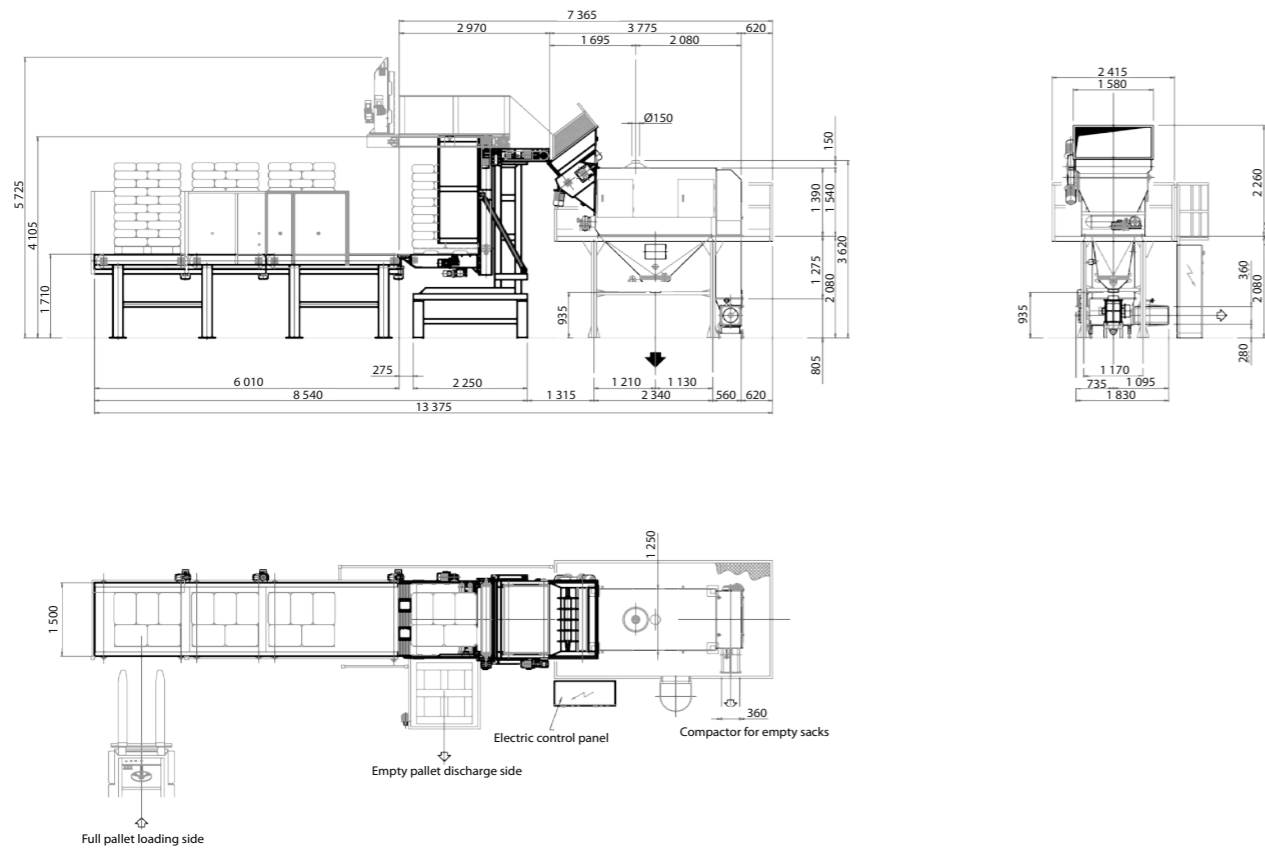

▶ STRENGTHS



Sacks conveyor for the transport of pallets to the cutting system



Empty sack compactor for a clean working area



Automatic unstacker for a loading of the pallet without operator's intervention



Vibrating chute to ease and control the flow of the material

▶ MEDIAS

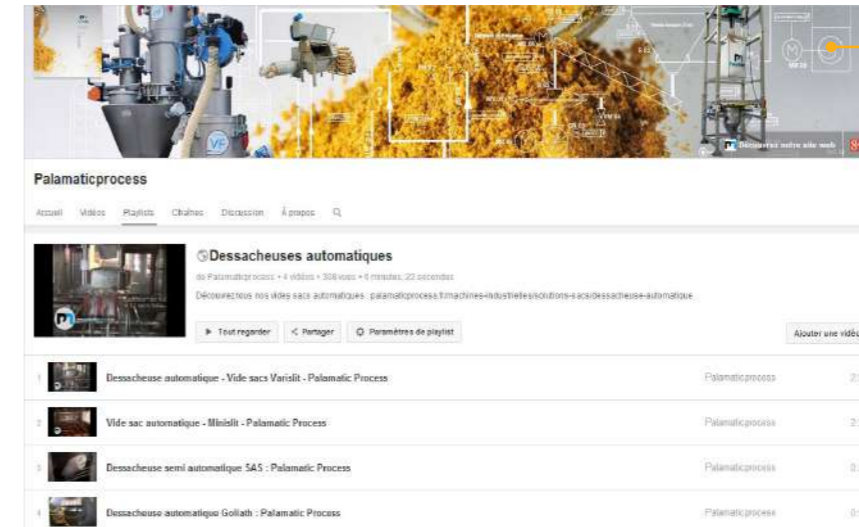

Discover our machines on our YouTube channel



▶ EXAMPLE OF IMPLEMENTATION

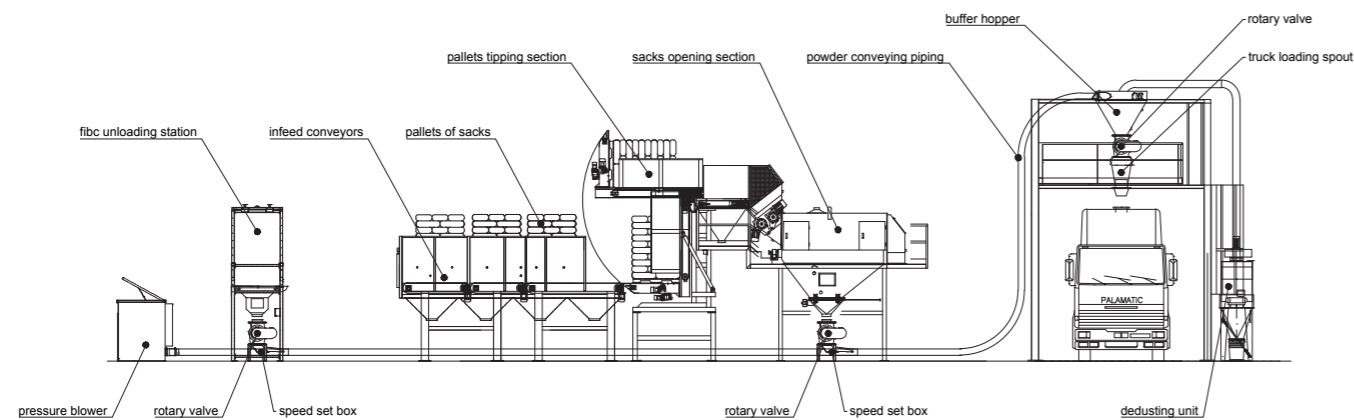

▶ PRIOR INSTALLATIONS



▶ Sack opening line at a polyethylene manufacturer



▶ Plastic injection plant



▶ Feeding of the plant by extrusion

TO GRIP, TO LIFT, TO MOVE AND TO EMPTY A METAL OR PLASTIC DRUM

Our handling tools allow easy handling, lifting, turning and emptying of drums and barrels. Thanks to our many options available, the operator can completely or partially empty the contents of drums into hoppers, reactors or mixers manholes. PALAMATIC PROCESS design office offers multiple solutions to manually or automatically empty drums (tipping or turning system) according to your site constraints...



DrumFlow® 01
Suction pipe

- Emptying directly on the pallet, without drum manipulation
- Suction by VFlow® pneumatic conveying range

[+] Advantages

- No drum manipulation
- All sizes
- Ease of use

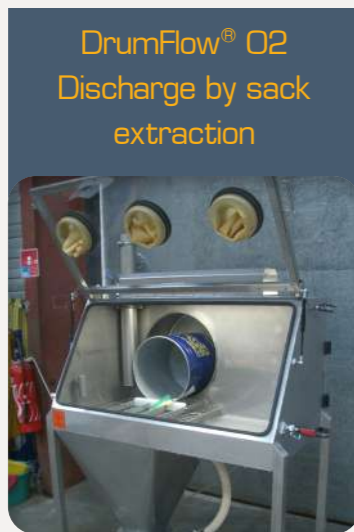

DrumFlow® 02
Discharge by sack extraction

- Confined dump station
- Drum connection on dump enclosure
- Removal of the inner sack layer for emptying

[+] Advantages

- Containment
- Possibility for empty sacks
- Raw material dosing



DrumFlow® 03
Tilting

- Emptying by tilting directly on a collecting hopper
- Options: suction booth, handling conveyor, facilitated product flowing

[+] Advantages

- All sizes
- No drum manipulation



DrumFlow® 04
Tilting and containment

- Completely confined emptying by means of containment and sealed connection

[+] Advantages

- Total containment
- No manipulations
- CMR toxic products applications

01 SUCTION PIPE



Drum discharging for mixer feeding

The suction pipe allows the vacuum of the material with a manual operation. This suction pipe is ideal for emptying drums. This system is intended to be coupled with our powder pumps from our VFlow® range to discover in our "Pneumatic Conveying" booklet. Vacuum is directly conducted into the drum from the cyclone. The flow rate varies from 100kg/h. to 2t./h. depending on the model of cyclone chosen. Optionally, the drum or cyclone can be implemented on a weighing system allowing the weighing and the dosing.

[+] Advantage

The DrumFlow® 01 solution prevents the operator from handling the drums that can be left on the pallet

[+] Advantage

Integration of a weighing device, weight gain or loss-in-weight



Discharge of end products stored in drums to feed a packing system

02 DISCHARGE BY SACK EXTRACTION

DISCHARGING AND DOSING BOOTH FOR RAW MATERIAL PACKAGED IN DRUMS

The discharge operation of the drums is carried out by the operator. Once the drum is positioned at the level of the enclosure, the operator extracts the sack to ensure its deconditioning and/or the dosing of the desired amount.



Operating mode for an optimized containment

- 1 Drum positioning in deconditioning cabin
- 2 Drum containment by external sack
- 3 Container opening via glove ports and product discharge into the hopper (sieve)
- 4 Barrel evacuation in the sack and sack sealed closing (no contact with operator)

Alternative possible



Lifting and positioning of the drum in the booth is performed by the elevator integrated on the booth

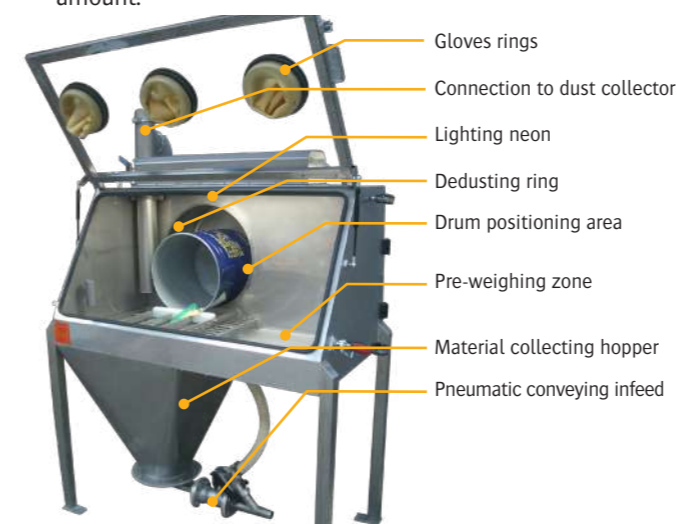

Our engineering office offers you turnkey customized solutions according to your product constraints, applications and drum dimensions.

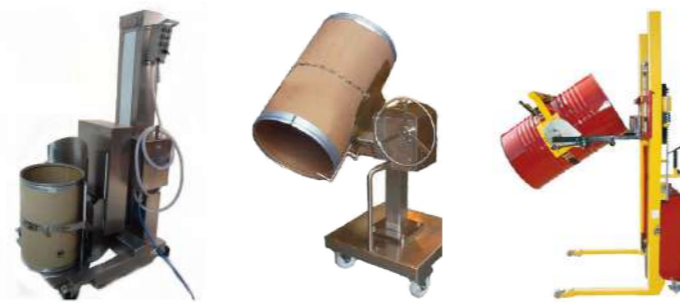
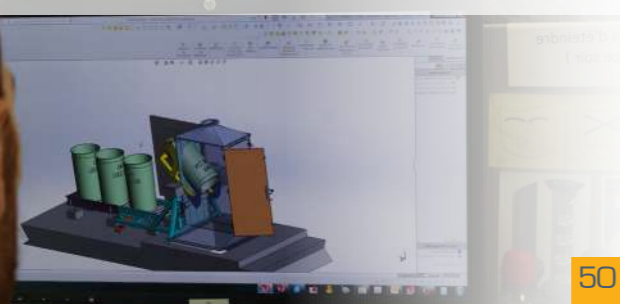

03 TIPPING

04 TIPPING AND TIGHT CAPPING

Advantages



Compatible with drums fitted with internal sack



Toxic products applications



Adjustable to all drum-types



Maximal containment enclosure for a healthy work-place

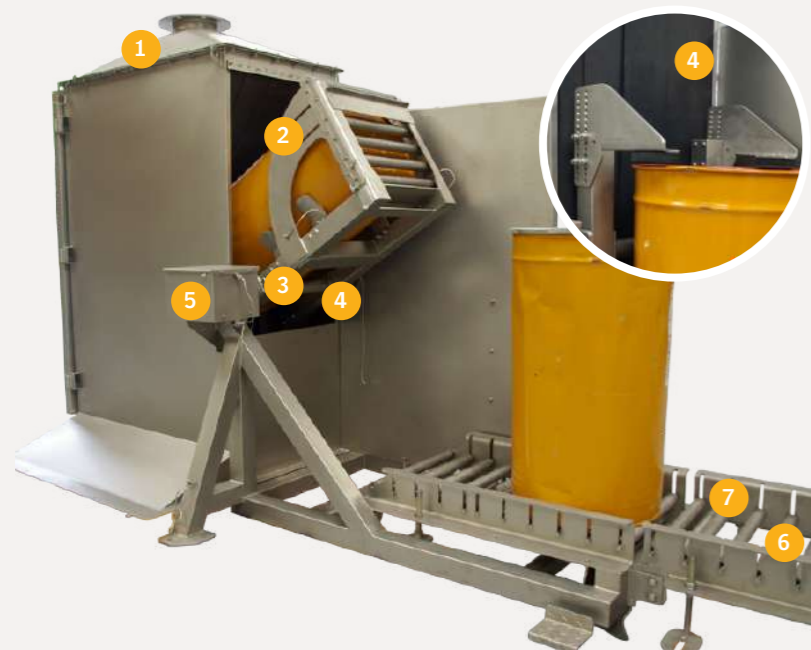

[+] Security

Protective screen

It is positioned near the tilting engine and guarantees the operator's security

Lock system

The cycle start is forbidden when the door is open

Control system

The control is conducted by "maintained" push buttons. The cycle is interrupted if the operator loses one of the buttons

Security area

Between the conveyor and the tipping device, it avoids all risks of collision and ensures the installation reliability

1. Hotte de capotage - 2. Tipping cradle with adjustable dimensions - 3. Arbre de basculement directly connected to engine - 4. Damper to maintain drum upper position during tipping (adjustable in height by monitoring system) - 5. Pivoting system with angular sensor - 6. Motorized roller conveyor - 7. Lifted frame for drum maintenance



1. Containment enclosure - 2. Flow aid vibrator - 3. Containment cylinder - 4. Gloves for drum opening - 5. Tipping cradle - 6. Bottom drum vibrator - 7. Motorized drum preparation conveyor - 8. Dump valve - 9. Connection inflatable seal - 10. Motorized switching group - 11. Isolation valve of the collecting hopper - 12. Collecting hopper - 13. Control panel - 14. Cabin with sectional door

TECHNICAL SPECIFICATION

Rate: 1 drum/4-5 min.

Manufacturing: framework in painted steel/stainless steel

Loading capacity: 250 kg

Angle: up to 180°

Drum tipping: electrical engine of 7,5 kW

Drum containment: pneumatic cylinder with sealing control by overpressure

Connection: by low-pressure inflatable seal

Draining butterfly valve: DN150

Product flow assistance: fluidiser on the discharge cone, vibrator on the cone or drum bottom

TECHNICAL SPECIFICATIONS

Rate : 1 barrel/2 min.

Manufacturing : framework in painted steel / stainless steel

Loading capacity: 180 kg

Angle : up to 180°

Drum tipping: electrical engine of 5,5 kW

OPERATION MODE

AVERAGE TIME OF A COMPLETE CYCLE: 2 MIN.

1. The drum positioning on the inlet conveyor.
2. The drums are led by gravity to the emptying area.
3. The first drum is put at the positioning stop; rubber pads ensure drum accommodation without any impact.
4. When the drum is positioned, the operator can start the tipping cycle. The control of the cycle is conducted by means of two push buttons for lifting and two buttons for descending of the drum. The tipping is ensured by a gearmotor. The moving assembly arrives to abutment against the rubber pads.
5. When emptied, drums return to their initial position under the operator's control.
6. The operator can then manually move the drums to the soiled drums station.

OPERATING MODE

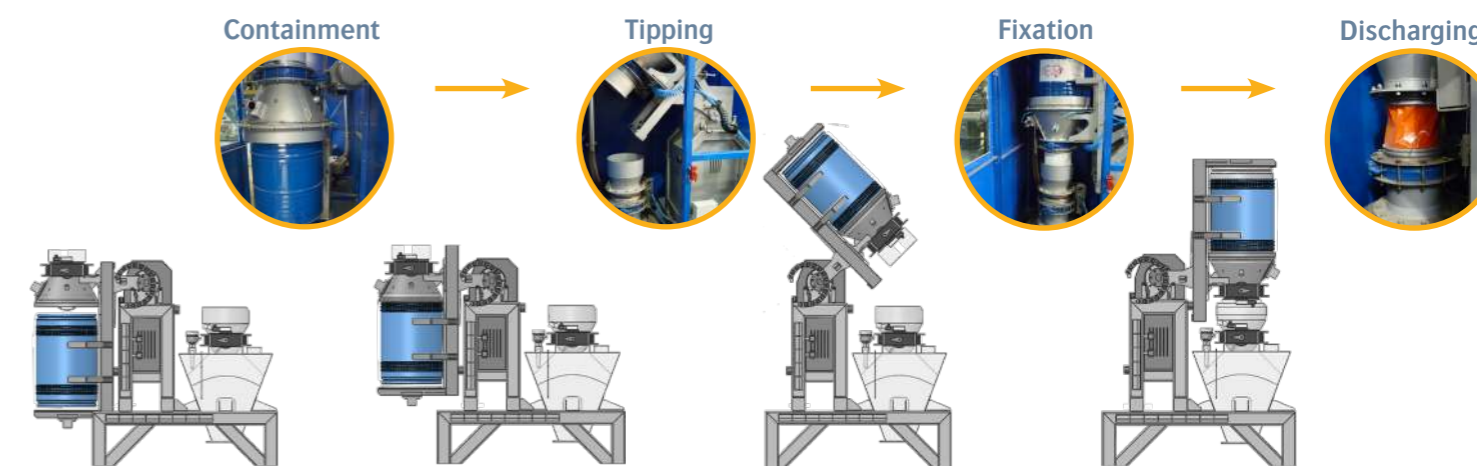

1. Drum placing on the inlet conveyor and on tipping cradle

2. Drum confinement is assured by cradle lifting on the containment cone. The internal cone forks prevent the reversal of the internal sack

3. Drum tilting

4. Connection to the hopper by means of inflatable seal and dump valves opening

Our expertise:

FILLING SOLUTIONS FOR BIG BAG AND OCTABIN

To fill

EMPTYING SOLUTIONS FOR BIG BAG AND OCTABIN

To empty, compact and massage

SACK, DRUM AND CARDBOARD FILLING SOLUTIONS

To fill, package, handle

SACK AND DRUM EMPTYING SOLUTIONS

To empty, compact, handle, discharge

SOLUTIONS FOR PNEUMATIC CONVEYING

Vacuum, pressure

SOLUTIONS FOR MECHANICAL CONVEYING

To transfer with screw, belt conveyor, bucket elevator, aeromechanical or vibratory conveyor, truck loading spout

CRUMBLING AND GRINDING EQUIPMENT

To granulate, crumble, grind, pound, micronise, disagglomerate

SIFTING EQUIPMENT

To sift, segregate, sieve, protect

CONTAINERS AND STORAGE SOLUTIONS

To fill, charge, empty, contain

DOSING EQUIPMENT

To control, regulate, empty, extract

MIXING EQUIPMENT

To homogenise, incorporate, fluidify, stir, mix

FLOW AND CONNECTION

To vibrate, fluidise, unclog, drain, facilitate extraction, control the descent, prevent stacks and vaults, connect

INDUSTRIAL DUST COLLECTING EQUIPMENT

To filter, clean, confine, secure



contact@palamatic.fr

Sales Department: +33 (0)2 22 93 63 08

ZA La Croix Rouge • 35530 Brécé • France

Tel: +33 (0)2 99 86 06 22 • Fax: +33 (0)2 99 86 08 10

SAS au capital de 331 822 euros • R.C.S. Rennes B 384 894 093 • APE 4669B • N° T.V.A. : FR 14 384 894 093