

# Vacuum Sack Lifter

Ex AVAILABLE CUSTOM MADE

## All Types of Sacks

### OBJECTIVES

Effortless vacuum lifting of all types of sacks from 10 to 80 kg and increased productivity. It is a simple and reliable means for one operator to handle sacks from 10 to 80 kg.

#### Advantages :

- Effortless lifting
- Maximum performance and productivity
- Optimal working conditions
- Improvement in ergonomics
- Increased operator safety
- Very little maintenance required

### EXAMPLES OF INSTALLATIONS

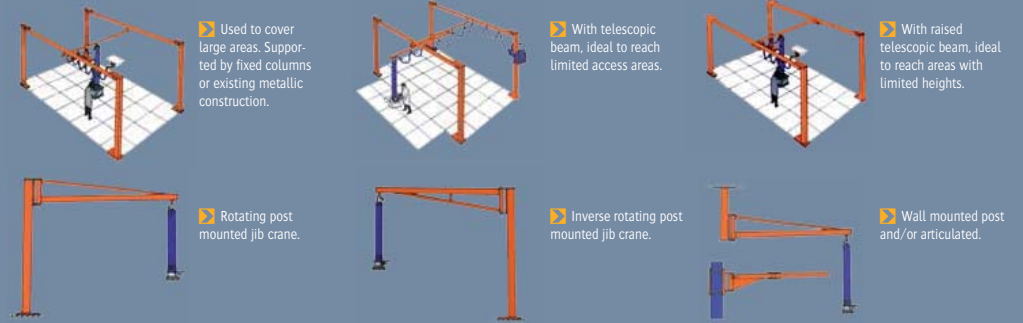

Triangular post mounted jib crane to provide a lifting stroke of 1,700 mm (overhead room 3m.)

Suction tube

360° rotation lifting tube

Lifting head

Large suction foot

Sack dumping unit



▶ Palletising: vacuum sack lifter with conveyor

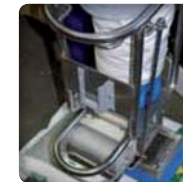

▶ Vacuum sack lifter: fitted with a control handle equipped with a stay-put lever valve allowing a self-stabilization of the load at any height, without any adjustment. Ergonomic handle design, preventing wrist elongation



▶ Rubber bale



▶ Hessian bags: vacuum gripper to lift sacks of grains

### Advantages

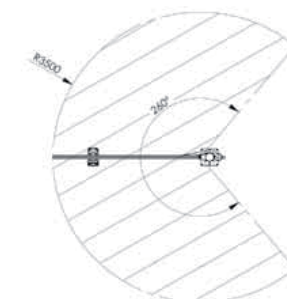
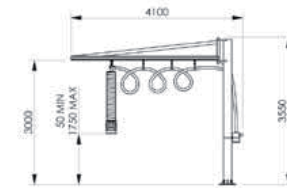
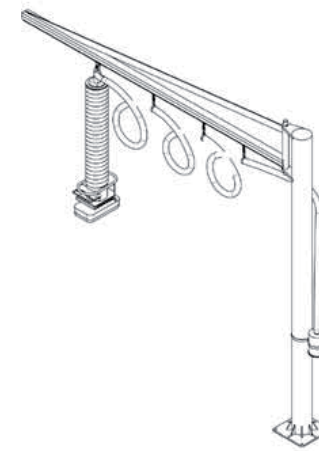

### Options



Protection cover



Oversized filter for dusty bags