

# Vertical Mixer



## Birotor

**Capacity:** 1,000 to 5,000 litres  
**Objectives:** efficient mixing at variable filling levels

### MIXING SOLUTION FOR DRY, MOIST AND VISCOUS MATERIALS

The double vertical shaft mixer offers a delicate treatment of dry, wet and sticky materials during mixing operations. The spiral blade of the vertical mixer activates a three-dimensional mixing of materials. This mixer can be used for dry powder, wet suspensions, liquid or pasty materials.

### TECHNICAL SPECIFICATIONS

- Vertical move of the product
- Soft brewing of all the contents
- High quality mixing and short cycles
- Filling level from 10% to 100% of the volume
- Minimum space between the walls and belt to prevent any product agglomeration
- No retention, continuous movement of the materials to be mixed



### DIMENSIONS in mm

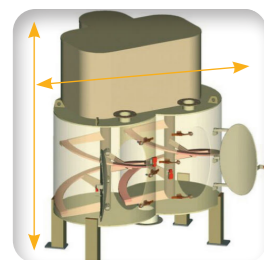
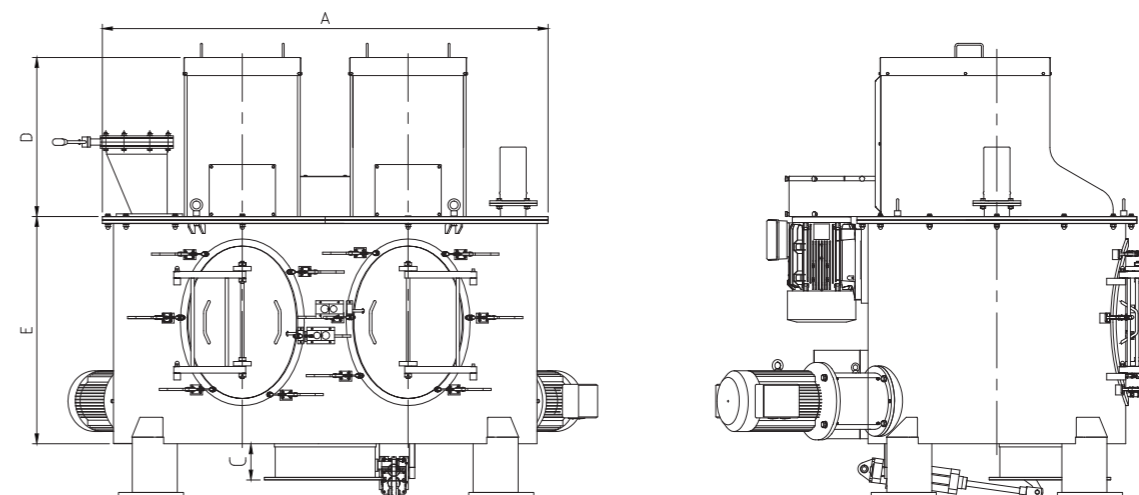

Compact size



External drive



Unloading valve



Large doors for maximal accessibility



Clean In Place (CIP)



Multiple materials inlets are possible



Polishing of welded components for hygienic finish



Can be installed on load cells for dosing

### Advantages

By its design, this type of mixer does not have any bearing in the product. Only two bearings, located on the upper part, ensure the guiding of the mixing shafts

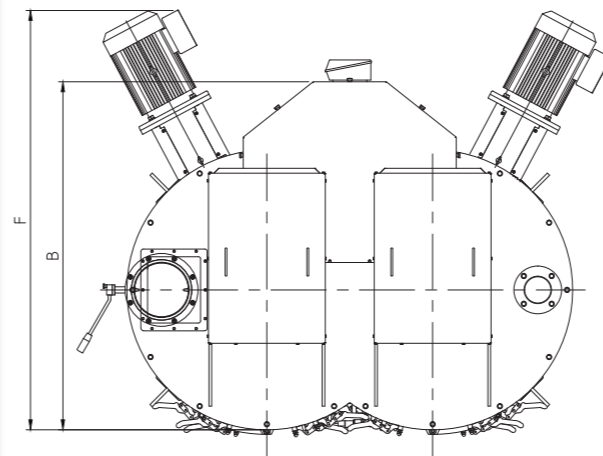

Models	Mixing capacity (L)	A	B	C	D	E	Power kW
VTM 1000	1,000	1,780	1,610	145	450	990	11
VTM 1500	1,500	1,950	1,760	145	520	1,140	15
VTM 2000	2,000	2,170	1,960	145	620	1,280	22
VTM 2500	2,500	2,500	1,935	145	710	1,250	22
VTM 3000	3,000	2,500	1,940	145	710	1,415	30
VTM 4000	4,000	2,780	2,140	145	710	1,560	37
VTM 5000	5,000	3,040	2,260	145	710	1,680	45

### Options



Load cells to inform the process about the amount of powder introduced



Inspection hatch

# Vertical Mixer



## Monorotor

Capacity: 500 to 4,000 litres

### HIGH MIXING QUALITY DUE TO THE THREE-DIMENSIONAL EFFECT

The vertical mixer with single shaft performs quality mixing of dry, moist and viscous materials. This mixer is ideal for the food industry as it complies with hygienic standards. It provides excellent mixing results, regardless of the materials to be mixed, through the helical movement of the central blade.

### DIMENSIONS in mm

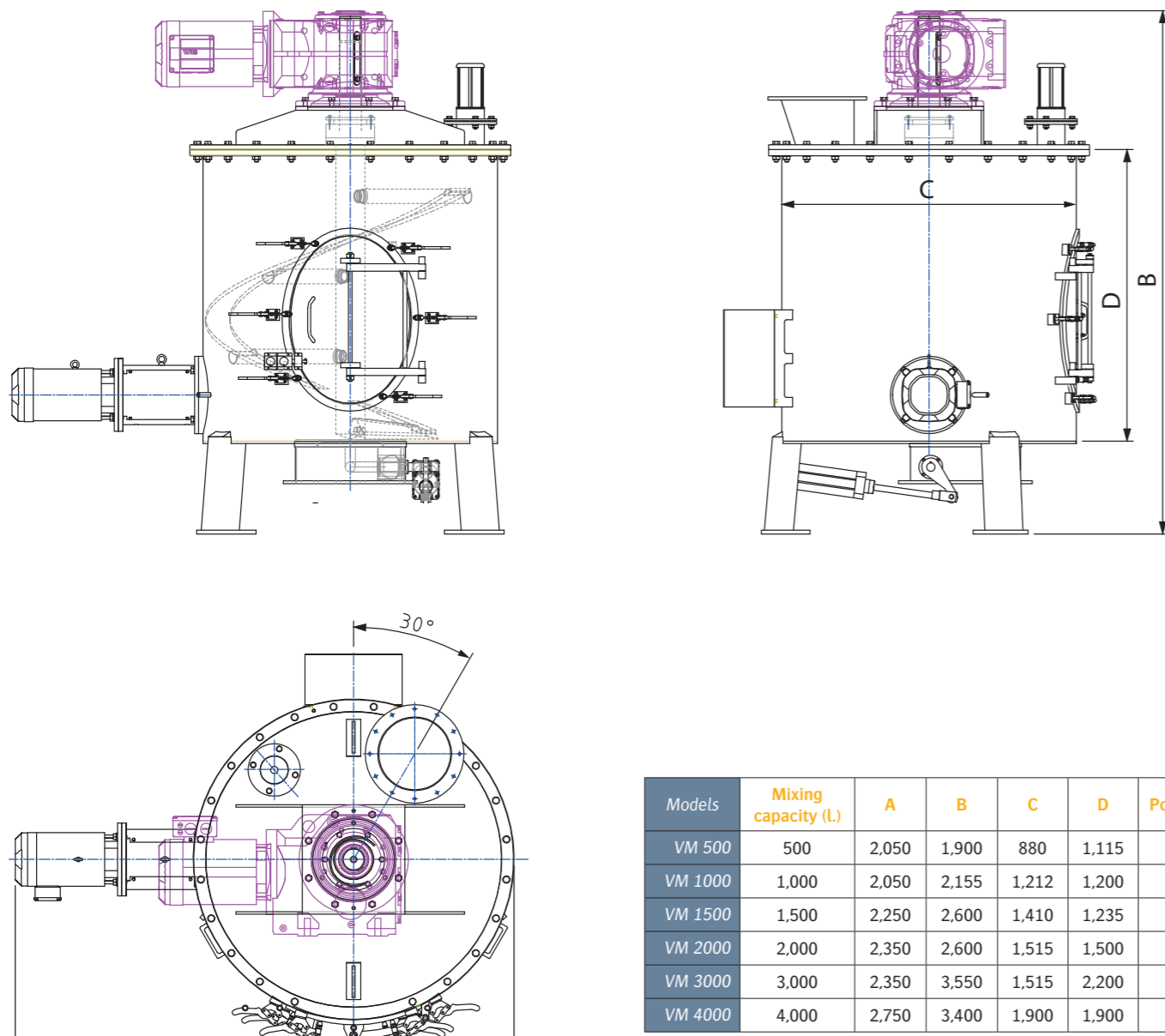

Models	Mixing capacity (L.)	A	B	C	D	Power kW
VM 500	500	2,050	1,900	880	1,115	7,5
VM 1000	1,000	2,050	2,155	1,212	1,200	11
VM 1500	1,500	2,250	2,600	1,410	1,235	11
VM 2000	2,000	2,350	2,600	1,515	1,500	15
VM 3000	3,000	2,350	3,550	1,515	2,200	22
VM 4000	4,000	2,750	3,400	1,900	1,900	30

## Case Studies



### MIXING LINE AND BABY FOOD HOMOGENIZATION

**Client:** Food factory

**Materials:** Milk powder and vitamins

**Installation details:** Loading of the ingredients packed in big bags and sacks with pre-weighing in a dedicated room to ensure complete hygiene.



### PRODUCING A PREMIX FOR SPREAD MANUFACTURING

**Client :** Dairy products

**Materials:** Milk powder, sugar, alginate cocoa

**Installation details:** Preparation and mixing line with manufacturing in masked time for introduction into a powder disperser. This technology was chosen for its cleanability and sanitation characteristics considering the absence of bearing in the product. The prepared mixture is packed in containers thus allowing management of masked time.

